

Introduction

Course Teacher-
Fernaz Narin Nur,
Senior Lecturer.

NETWORKS

*A **network** is a set of devices (often referred to as **nodes**) connected by communication **links**. A node can be a computer, printer, or any other device capable of sending and/or receiving data generated by other nodes on the network.*

Uses of Computer Networks

- Business Applications
- Home Applications
- Mobile Users
- Social Issues

Business Applications of Networks

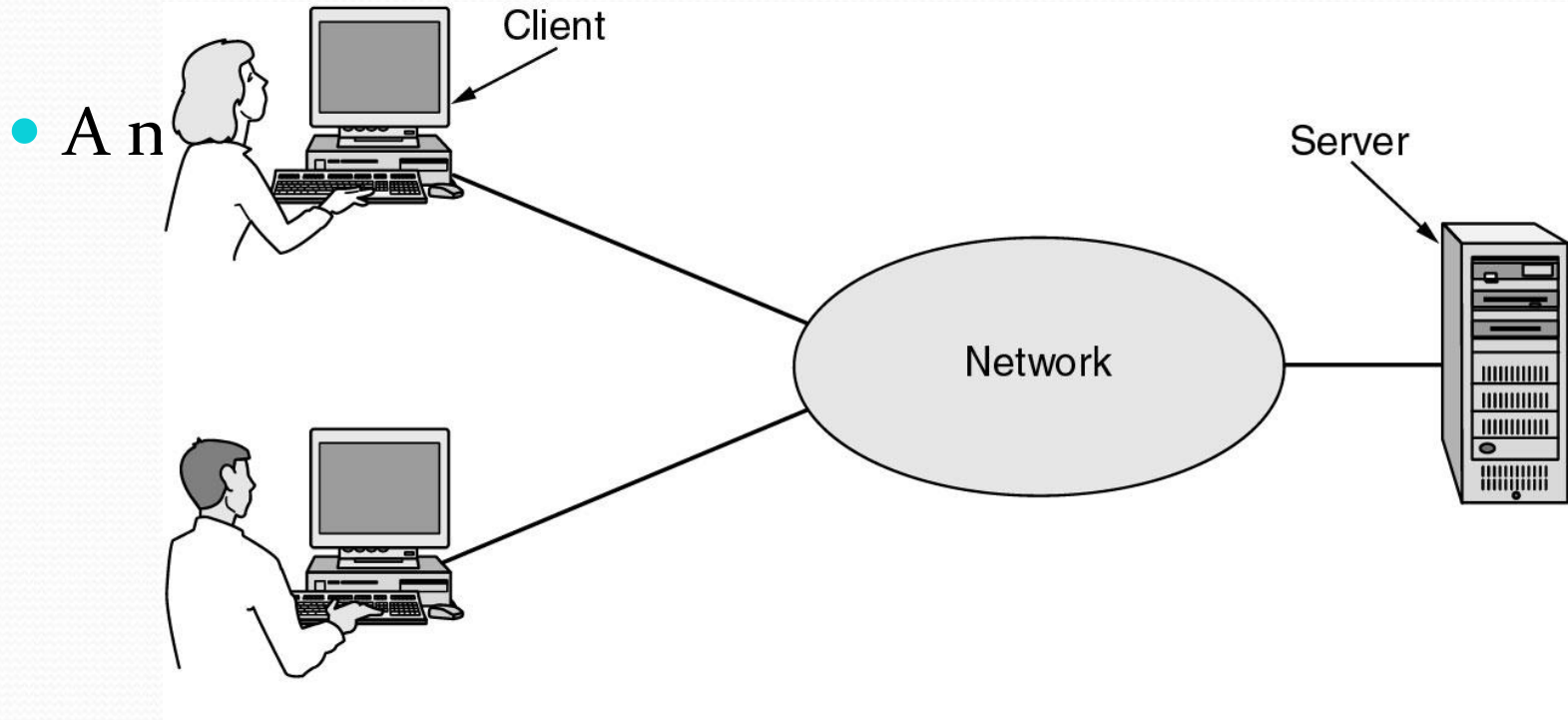

Business Applications of Networks

(2)

- The client-server model involves requests and replies.

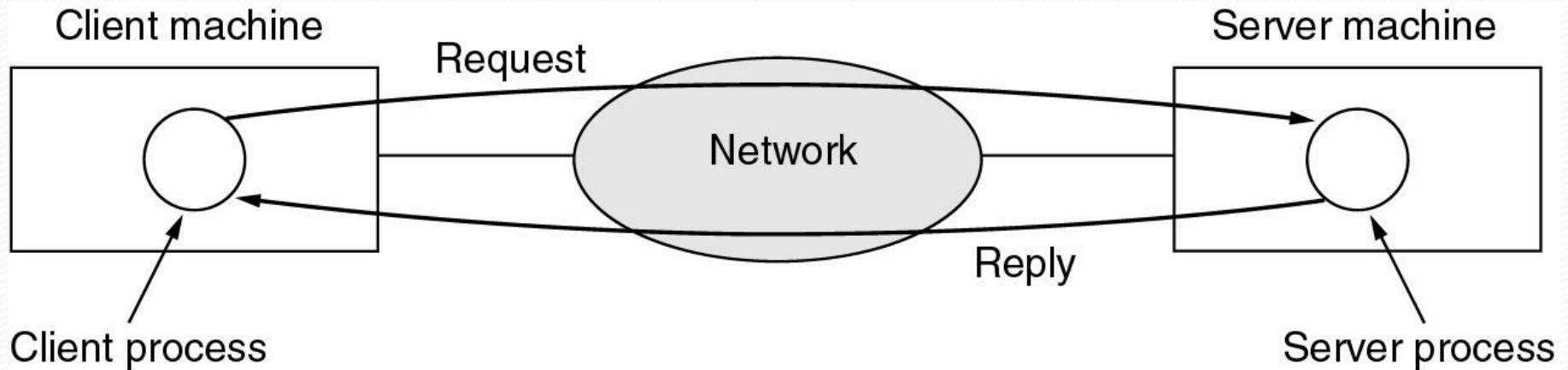

Home Network Applications

- Access to remote information
- Person-to-person communication
- Interactive entertainment
- Electronic commerce

Home Network Applications (2)

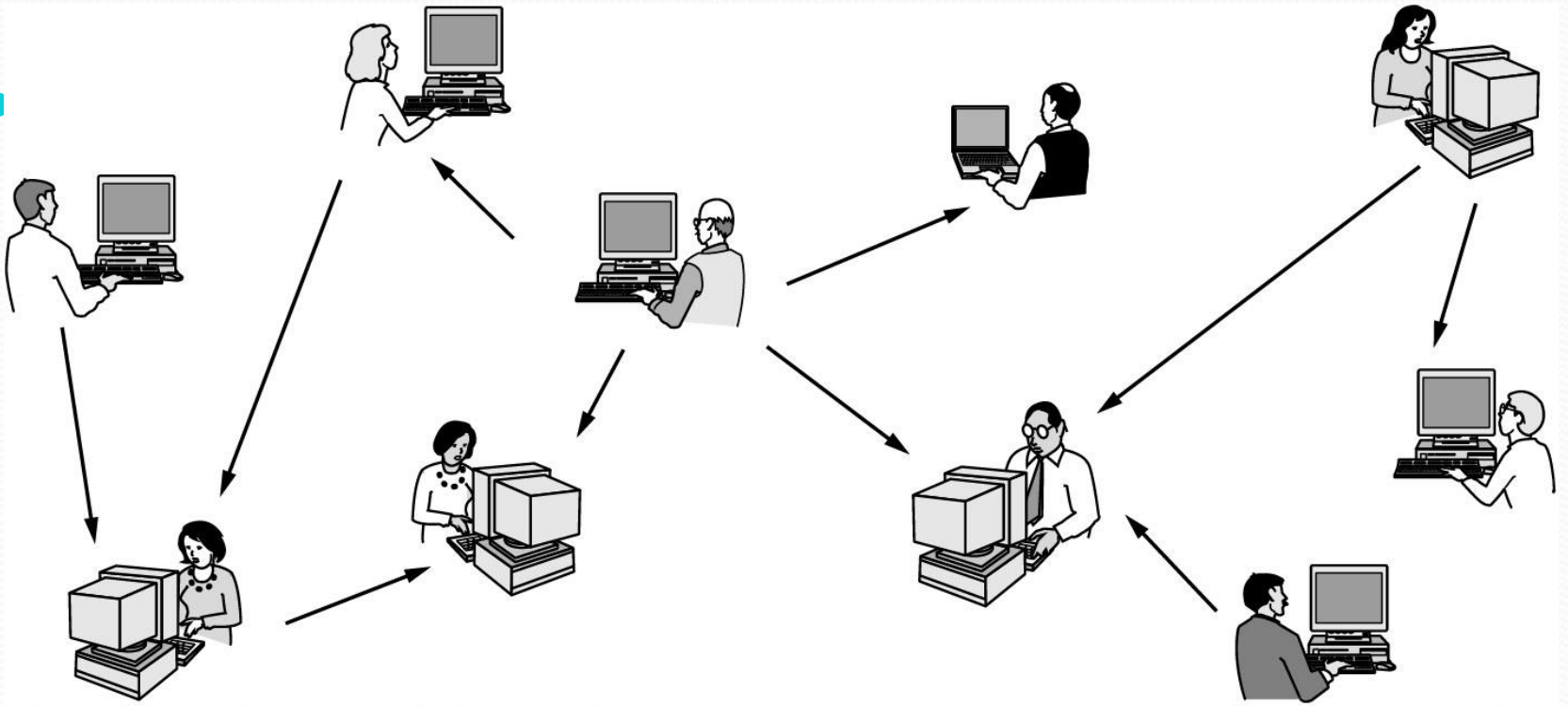

Home Network Applications (3)

- Some forms of e-commerce.

Tag	Full name	Example
B2C	Business-to-consumer	Ordering books on-line
B2B	Business-to-business	Car manufacturer ordering tires from supplier
G2C	Government-to-consumer	Government distributing tax forms electronically
C2C	Consumer-to-consumer	Auctioning second-hand products on-line
P2P	Peer-to-peer	File sharing

Network Hardware

- Local Area Networks
- Metropolitan Area Networks
- Wide Area Networks
- Wireless Networks
- Home Networks
- Internetworks

Local Area Networks

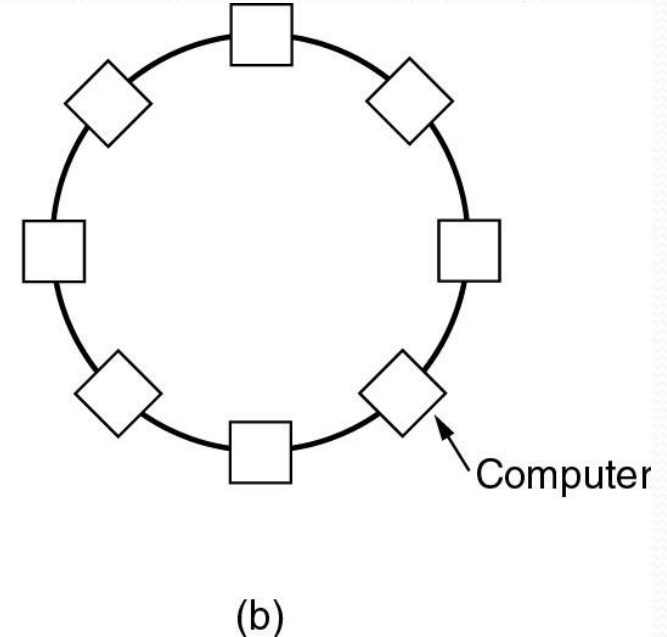
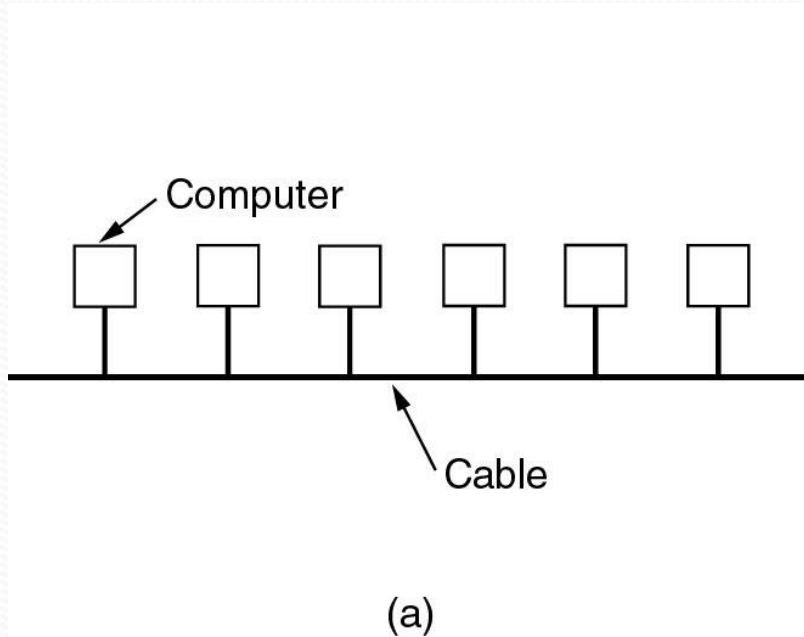

- Two broadcast networks
- (a) Bus
- (b) Ring

Metropolitan Area Networks

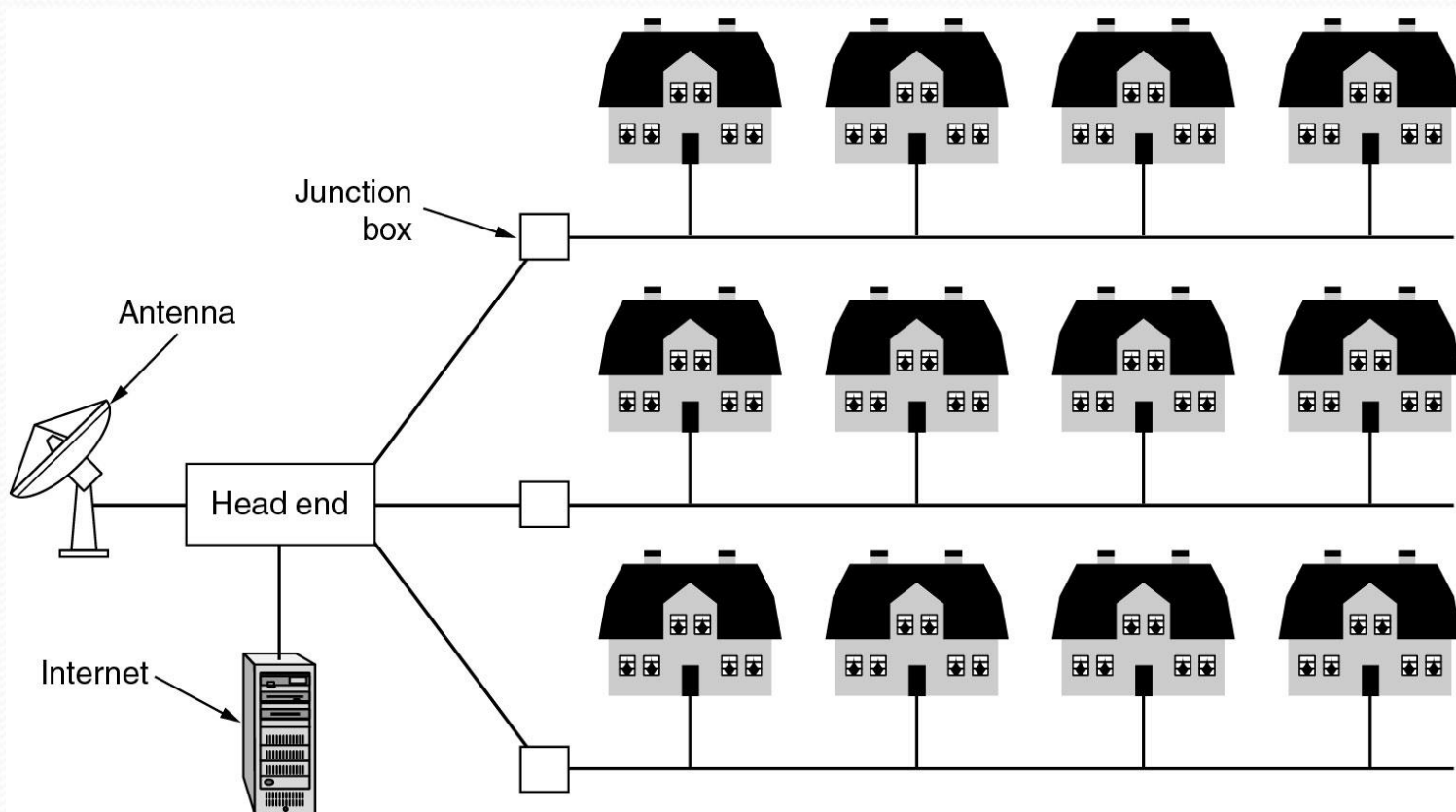

Wide Area Networks

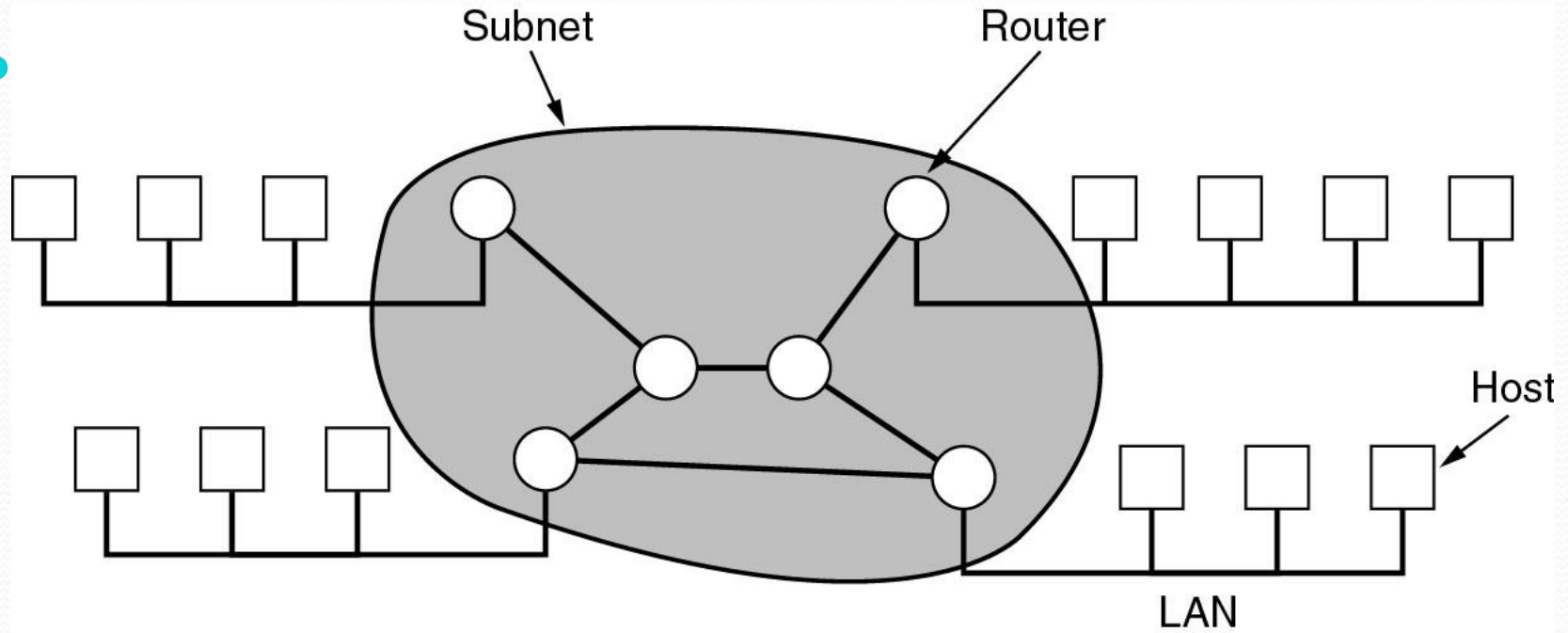

Wide Area Networks (2)

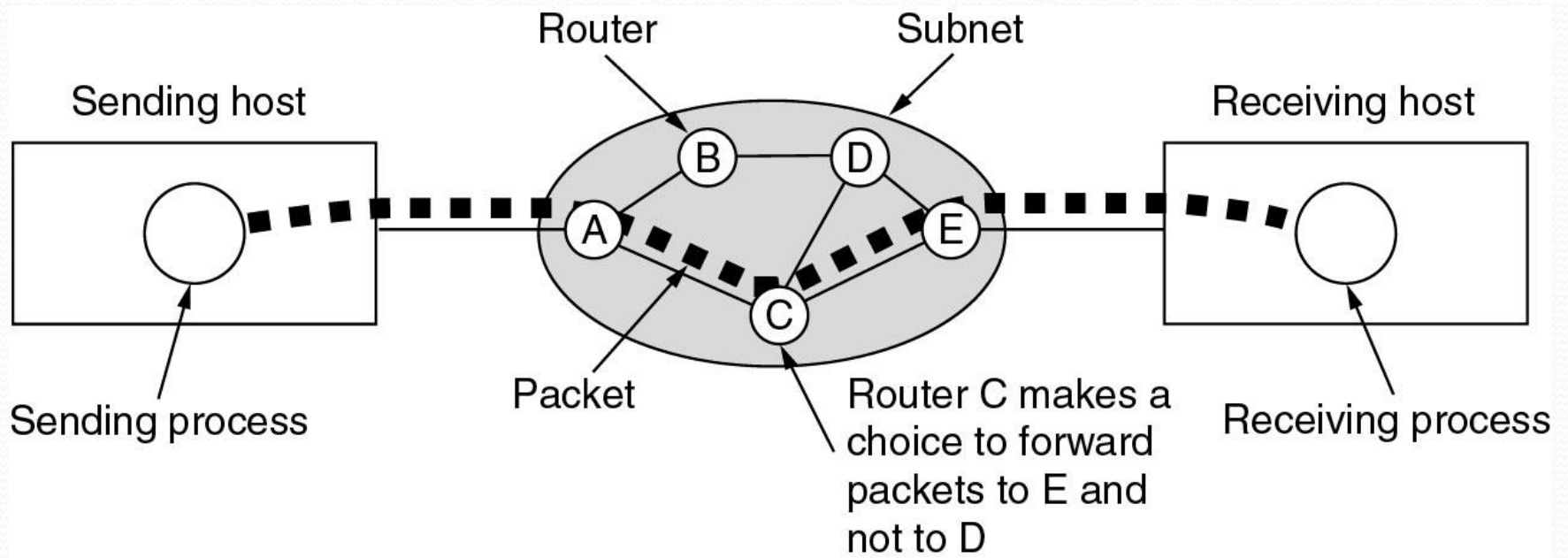

Wireless Networks

- Categories of wireless networks:
- System interconnection
- Wireless LANs
- Wireless WANs

Wireless Networks (2)

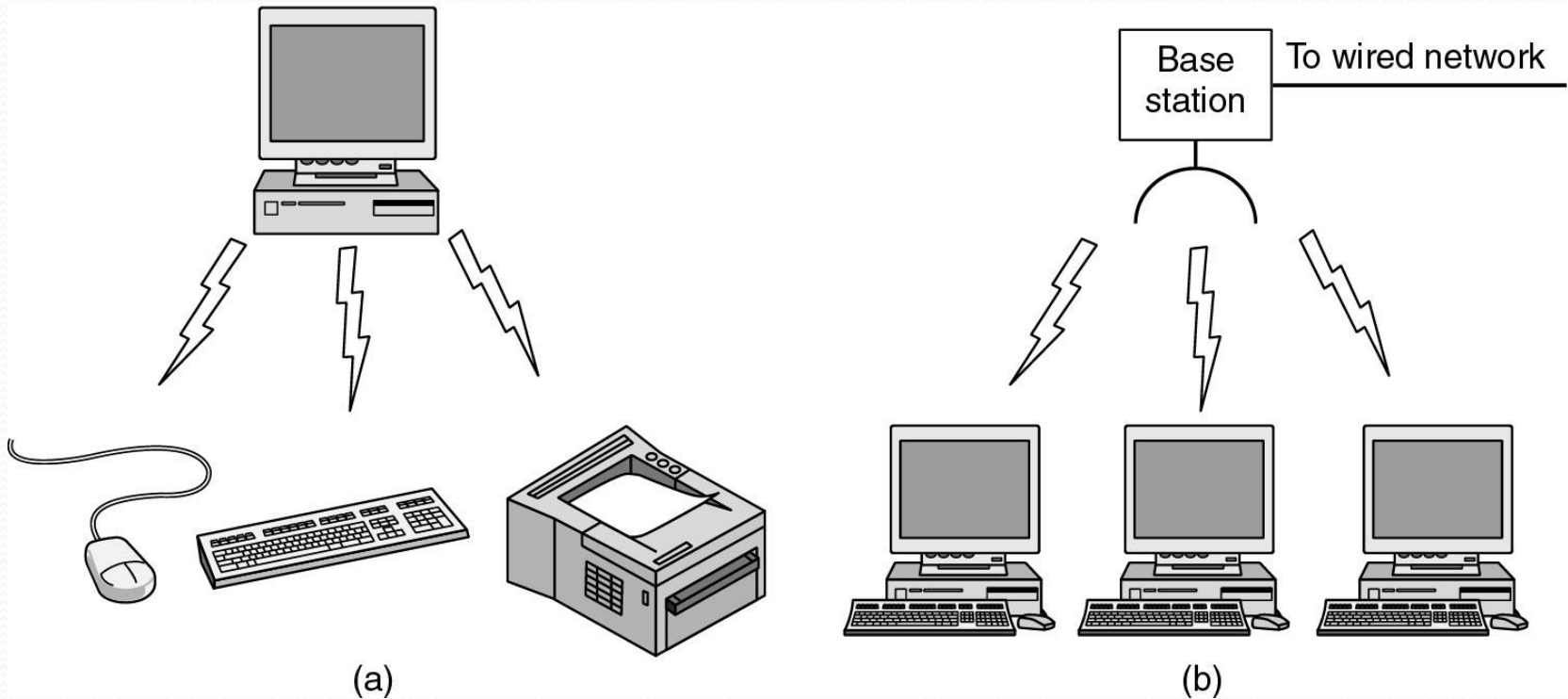

- (a) Bluetooth configuration
- (b) Wireless LAN

Types of connections: point-to-point and multipoint

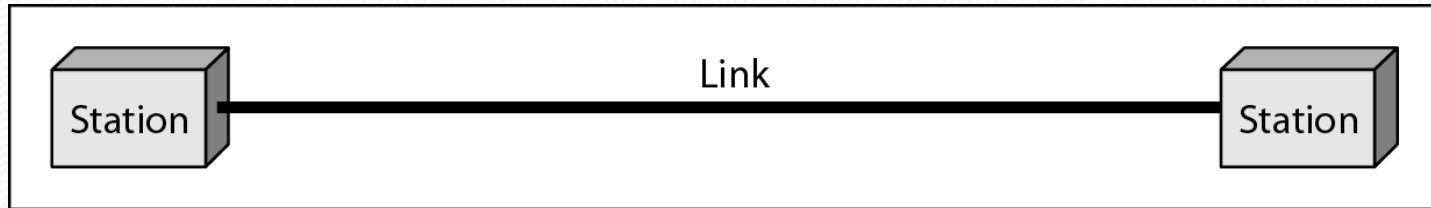

a. Point-to-point

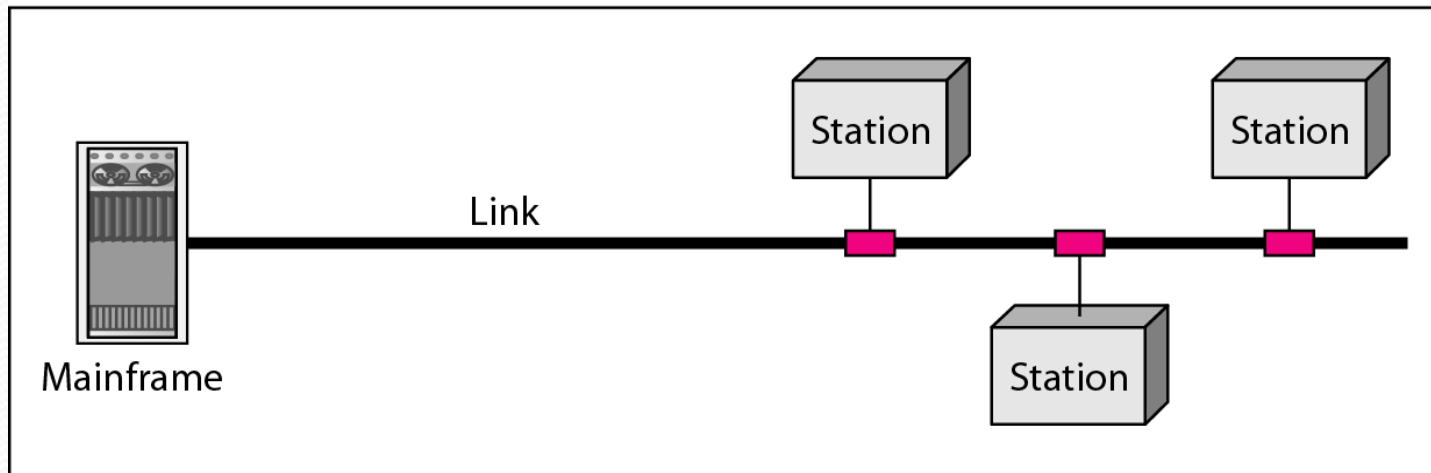

b. Multipoint

Categories of topology

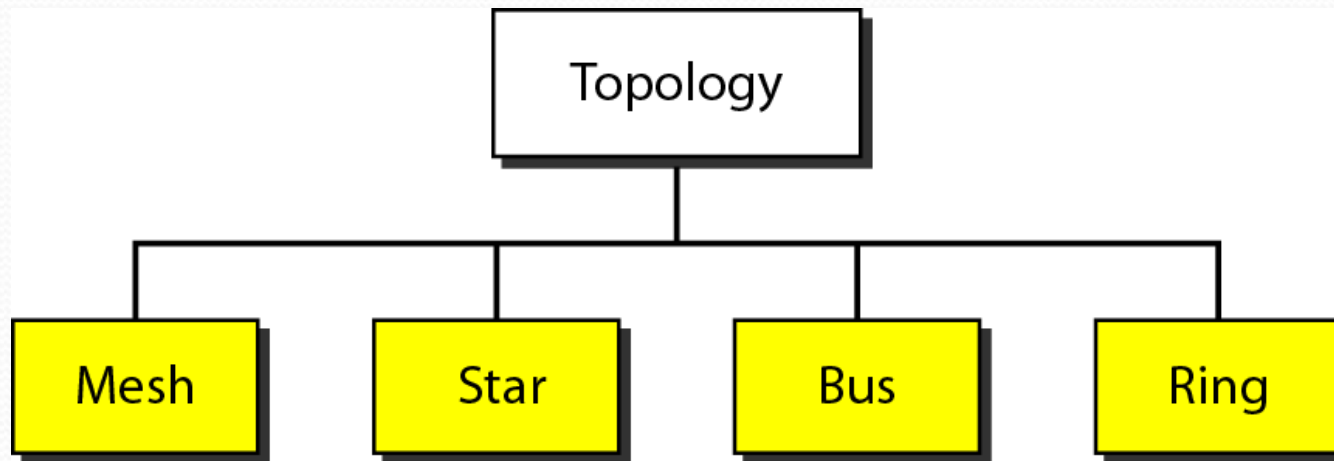

A fully connected mesh topology (five devices)

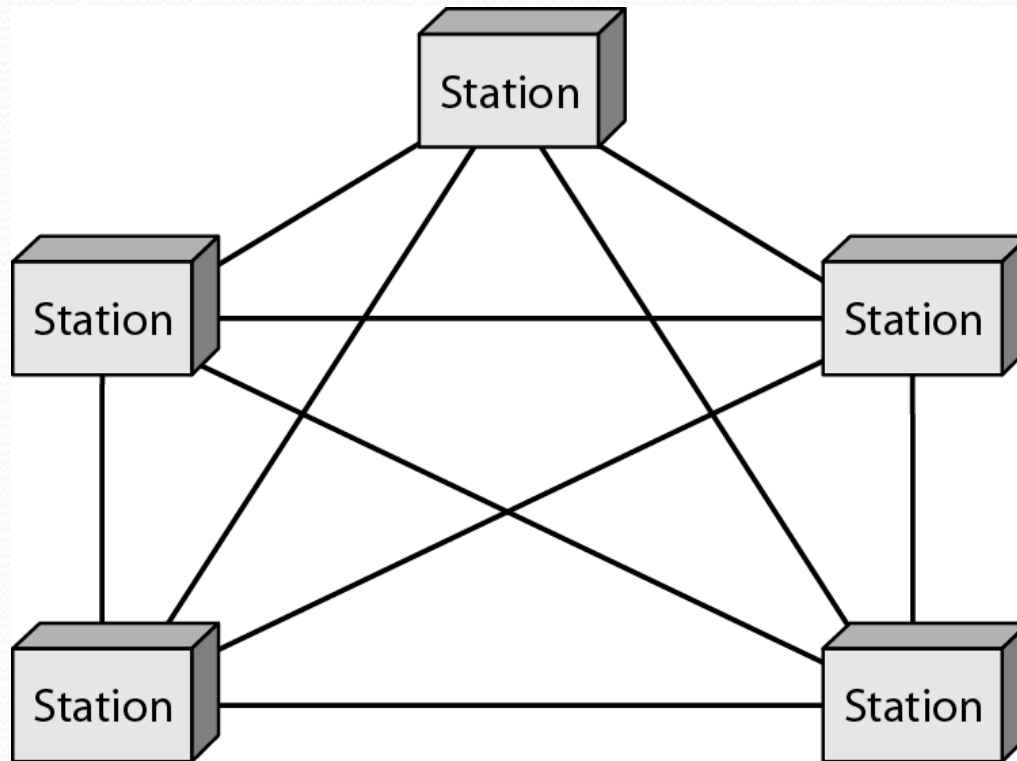

A star topology connecting four stations

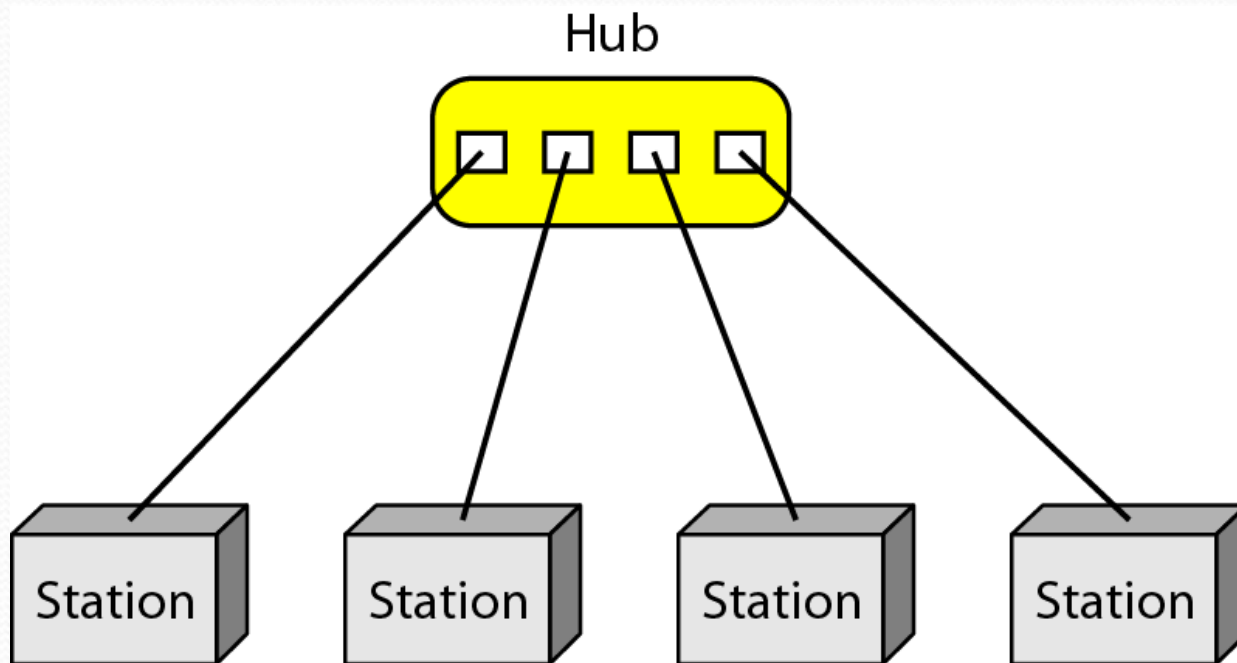

A bus topology connecting three stations

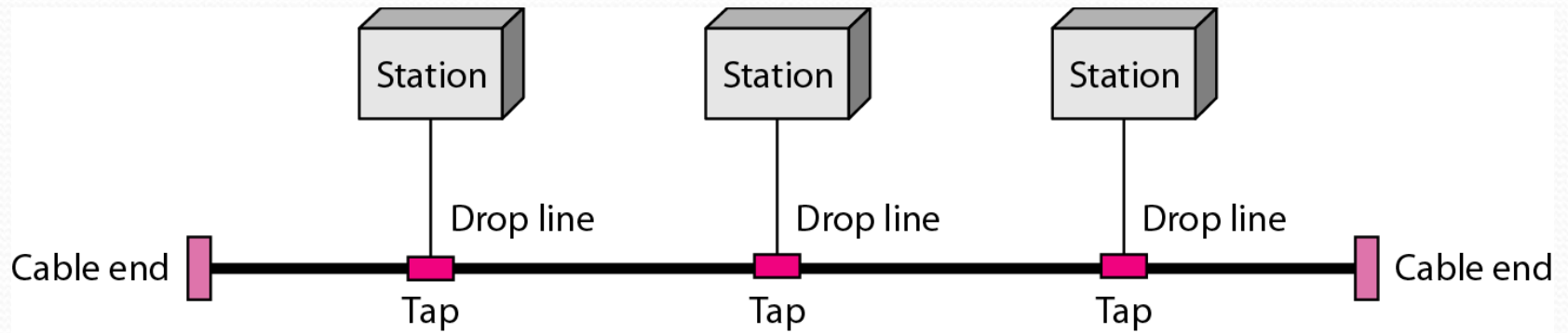

A ring topology connecting six stations

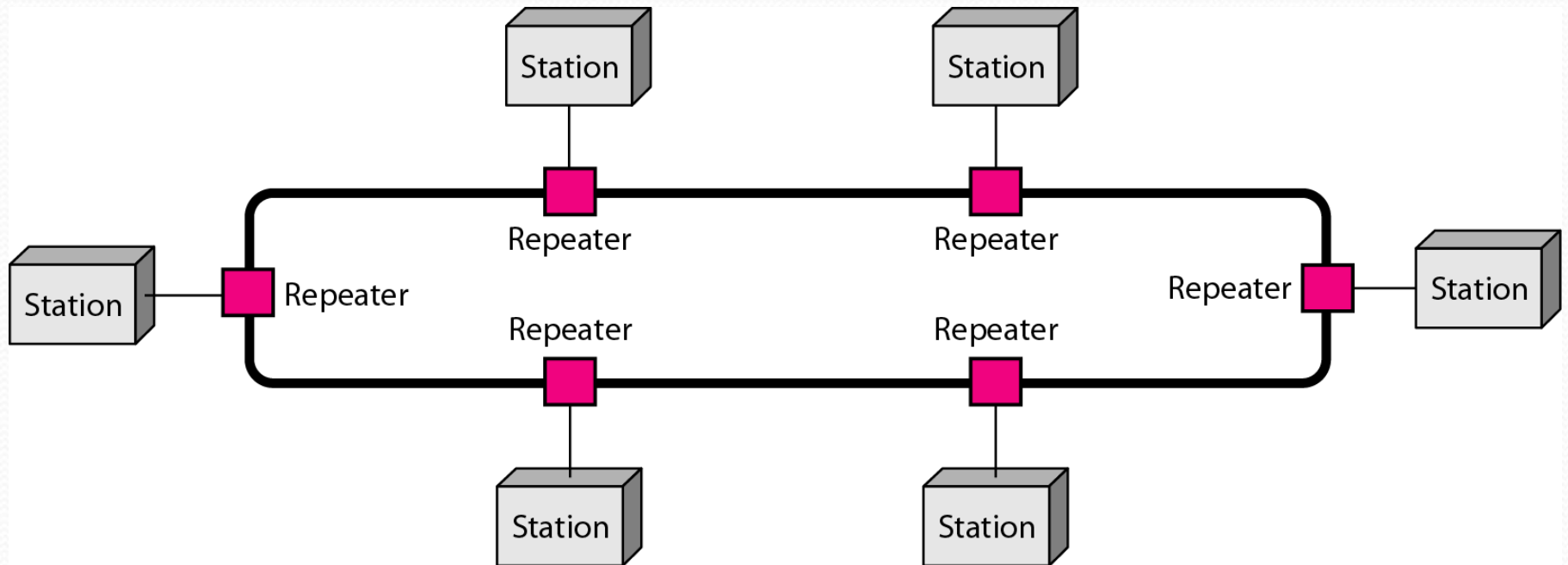

*A hybrid topology:
a star backbone with three bus networks*

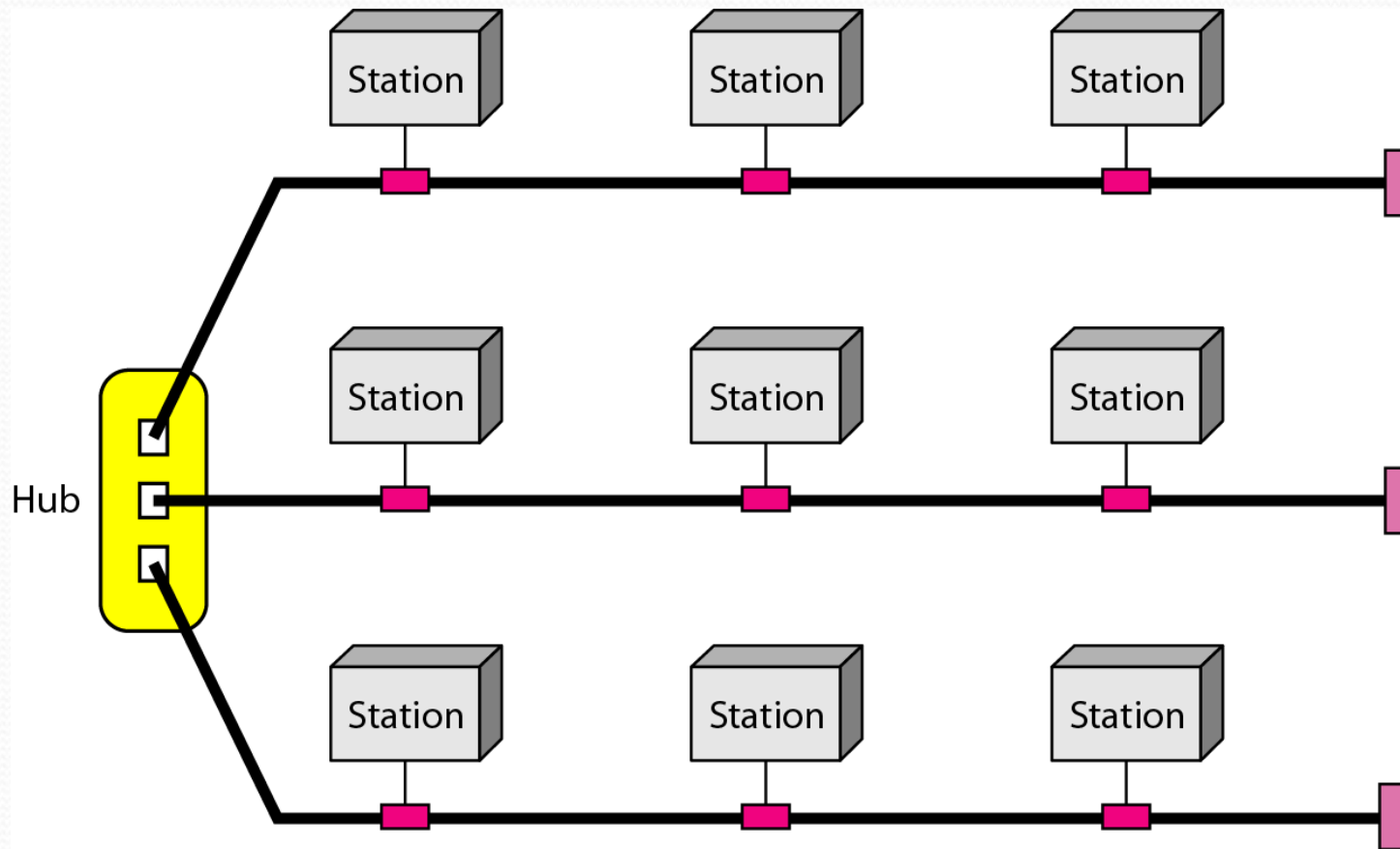

An isolated LAN

*connecting 12 computers to a hub
in a closet*

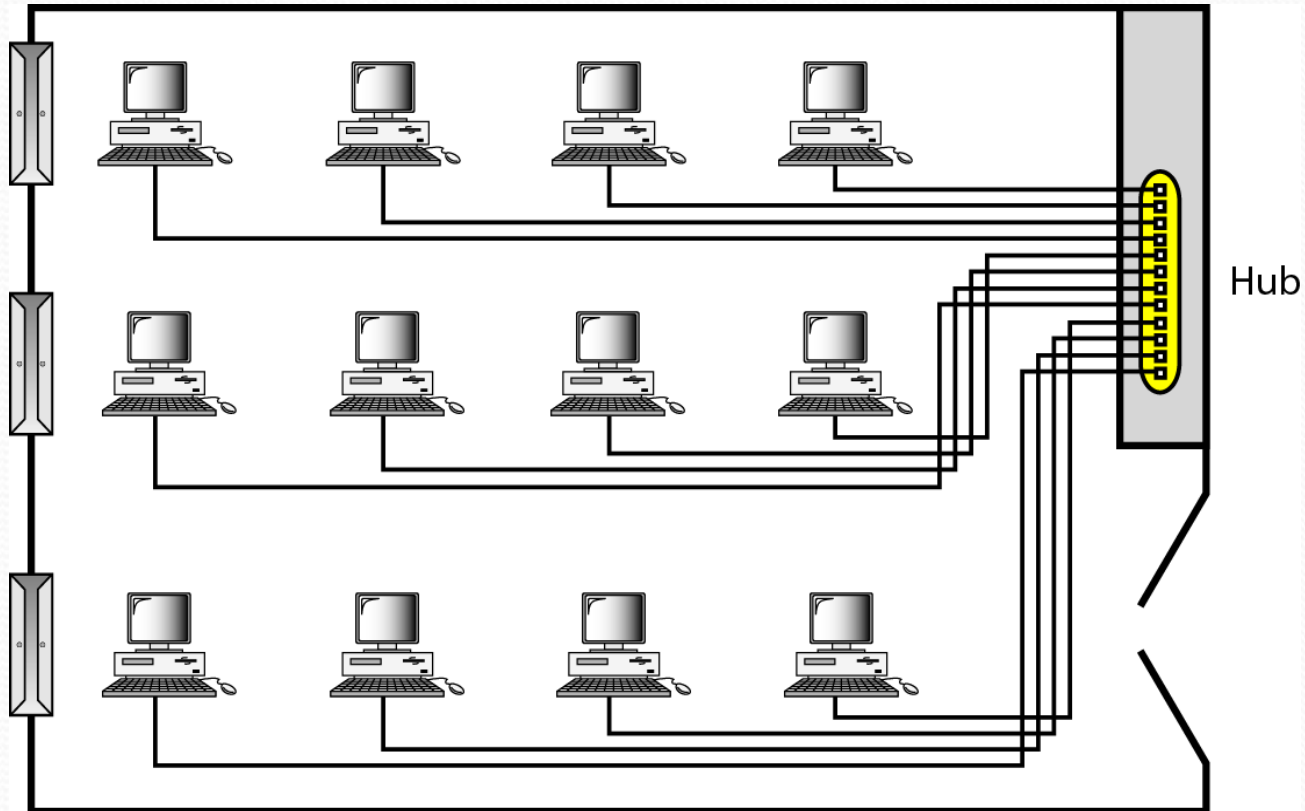

WANs: a switched WAN and a point-to-point WAN

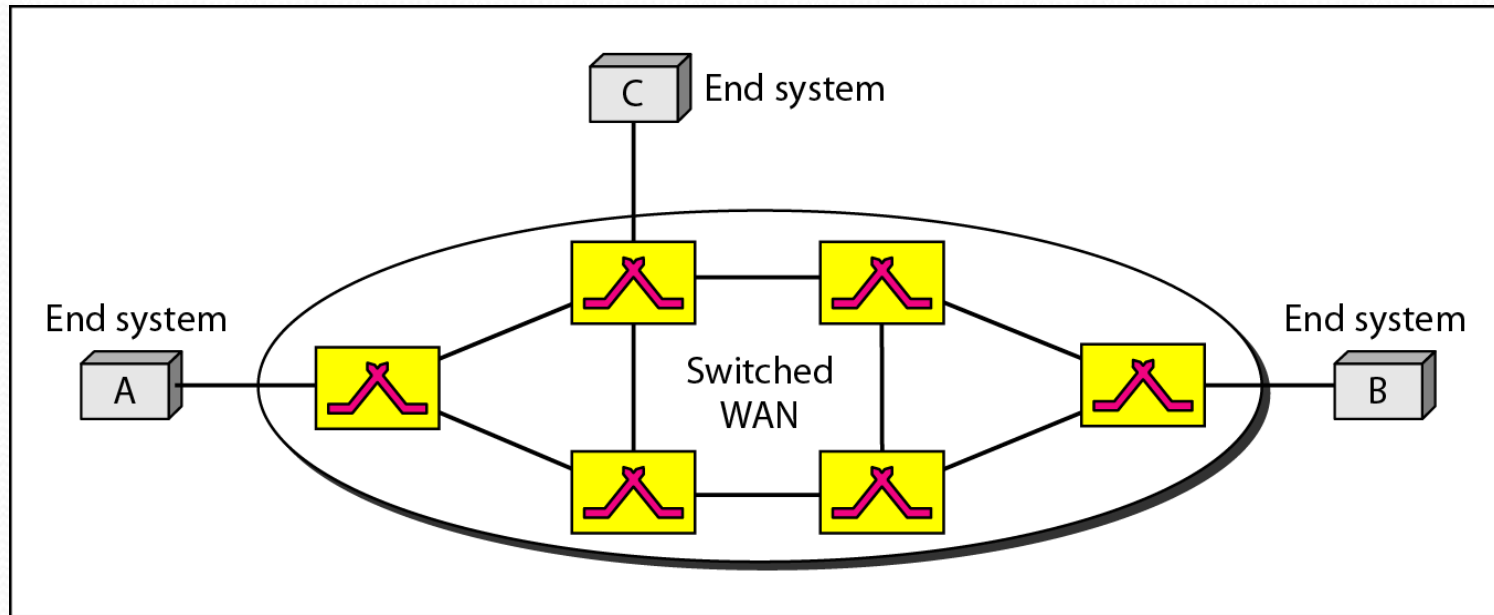

a. Switched WAN

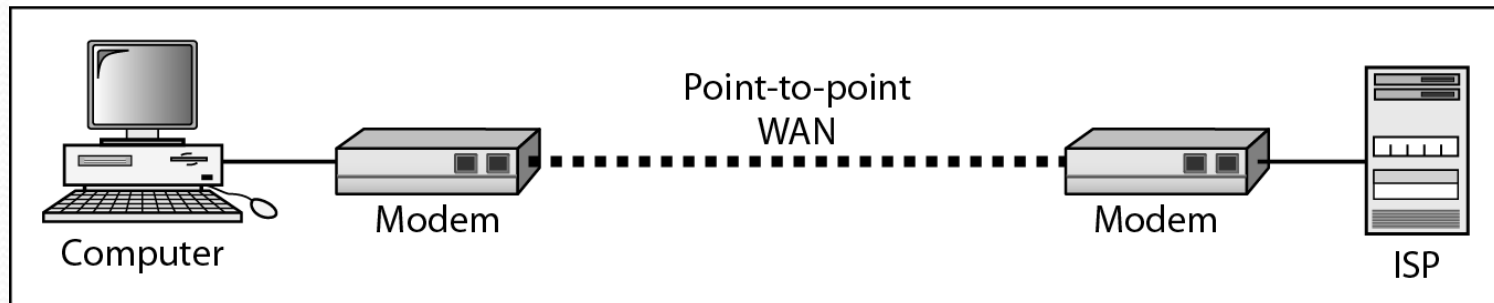

b. Point-to-point WAN

THE INTERNET

*The **Internet** has revolutionized many aspects of our daily lives. It has affected the way we do business as well as the way we spend our leisure time. The Internet is a communication system that has brought a wealth of information to our fingertips and organized it for our use.*

Hierarchical organization of the Internet

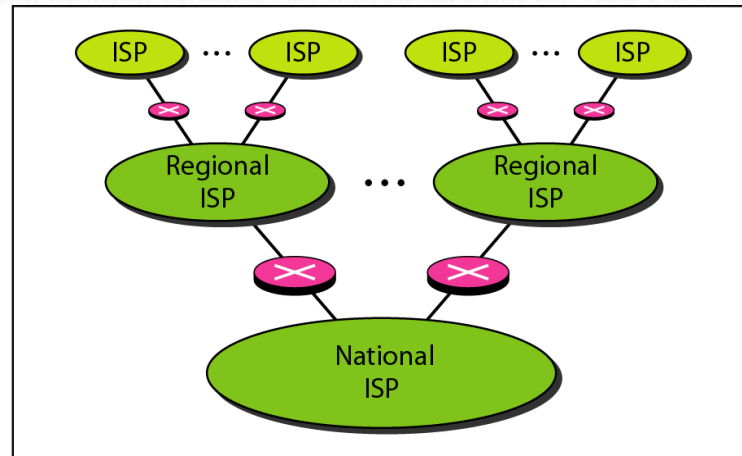

a. Structure of a national ISP

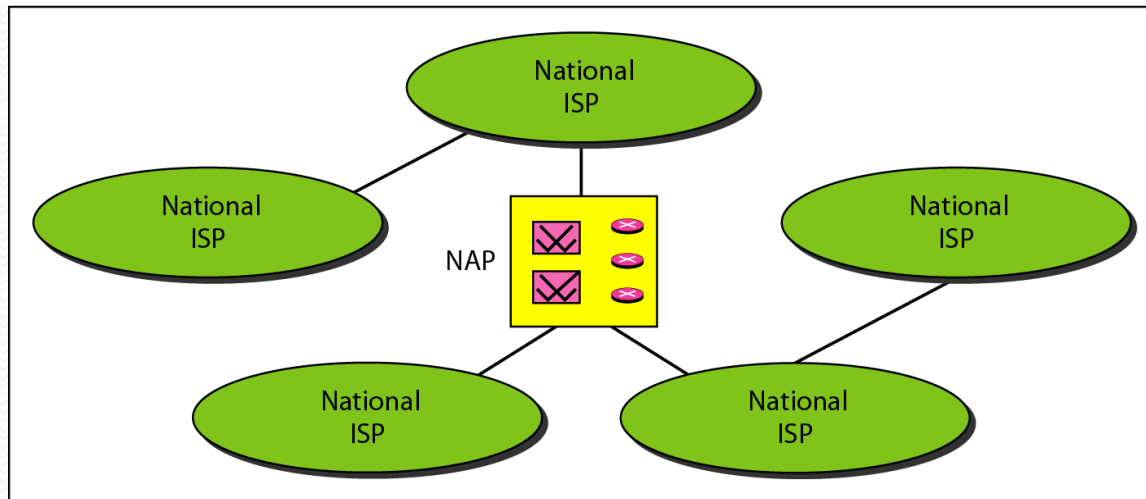

b. Interconnection of national ISPs



Network Models

LAYERED TASKS

*We use the concept of **layers** in our daily life. As an example, let us consider two friends who communicate through postal mail. The process of sending a letter to a friend would be complex if there were no services available from the post office.*

Tasks involved in sending a letter

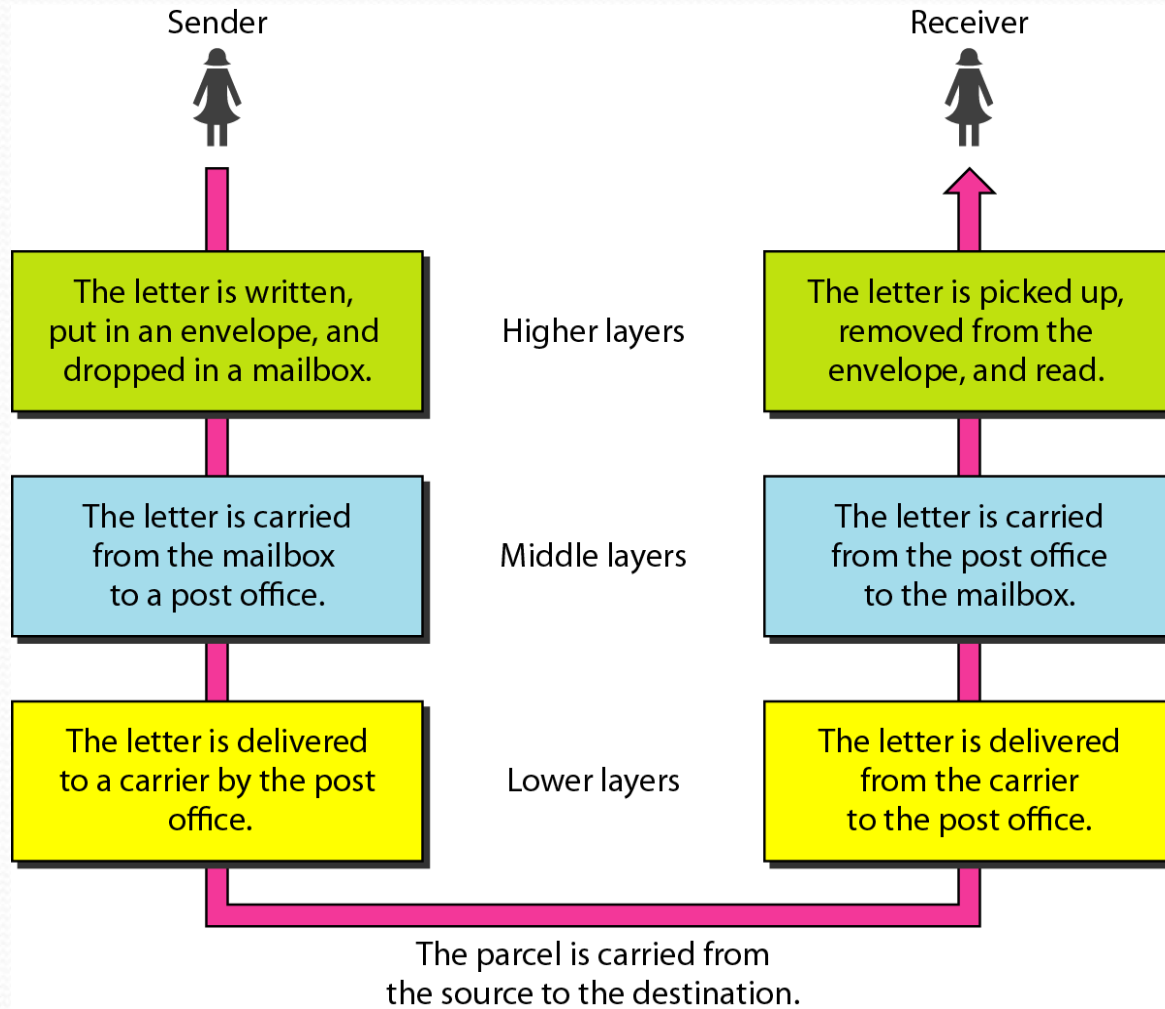

THE OSI MODEL

Established in 1947, the International Standards Organization (ISO) is a multinational body dedicated to worldwide agreement on international standards. An ISO standard that covers all aspects of network communications is the Open Systems Interconnection (OSI) model. It was first introduced in the late 1970s.

ISO is the organization.
OSI is the model.

Seven layers of the OSI model

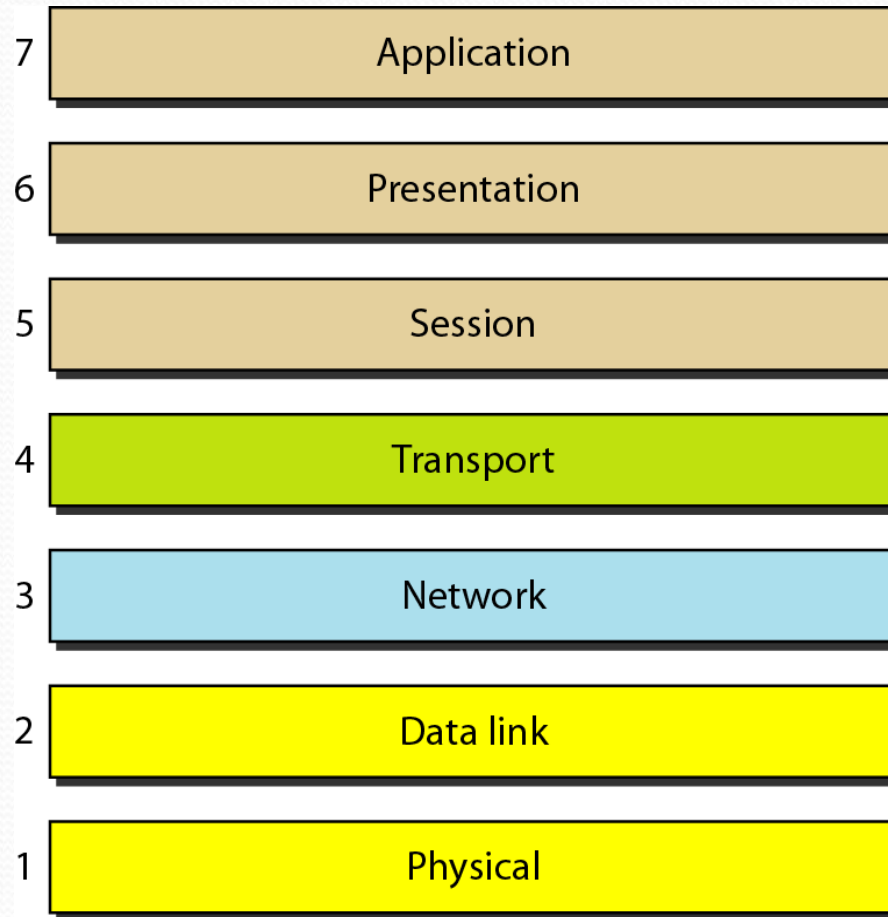

The interaction between layers in the OSI model

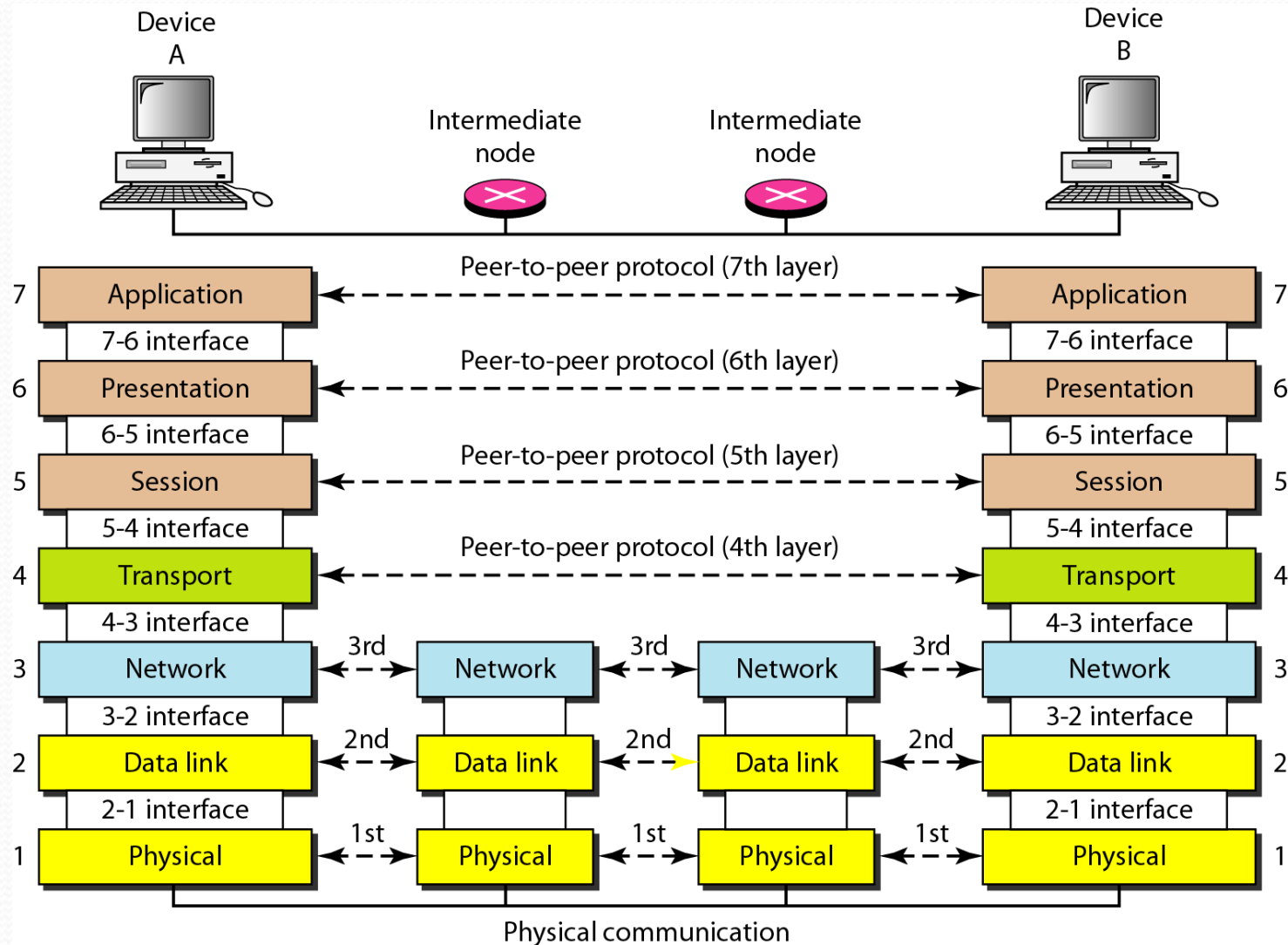

An exchange using the OSI model

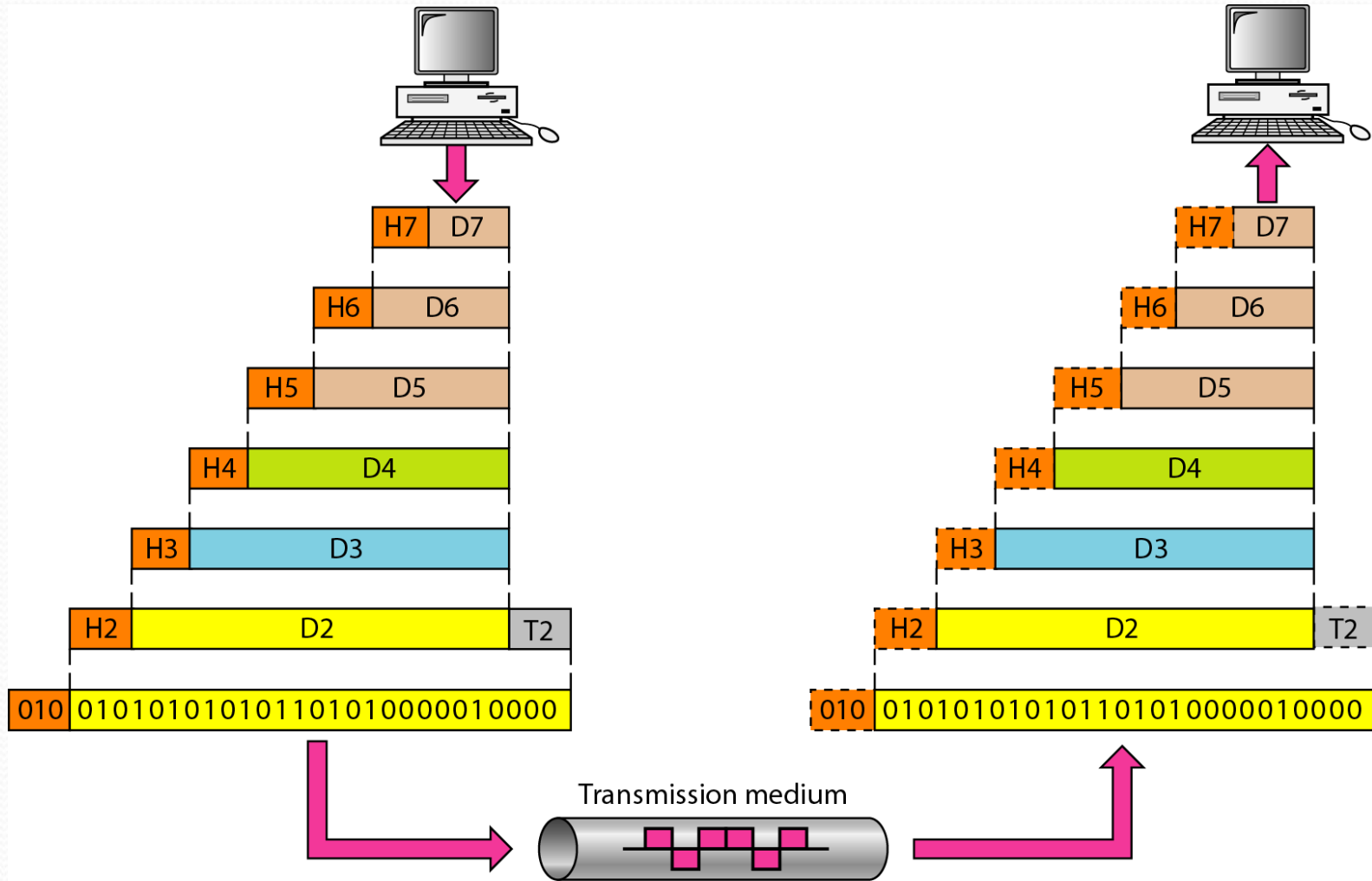

Physical layer

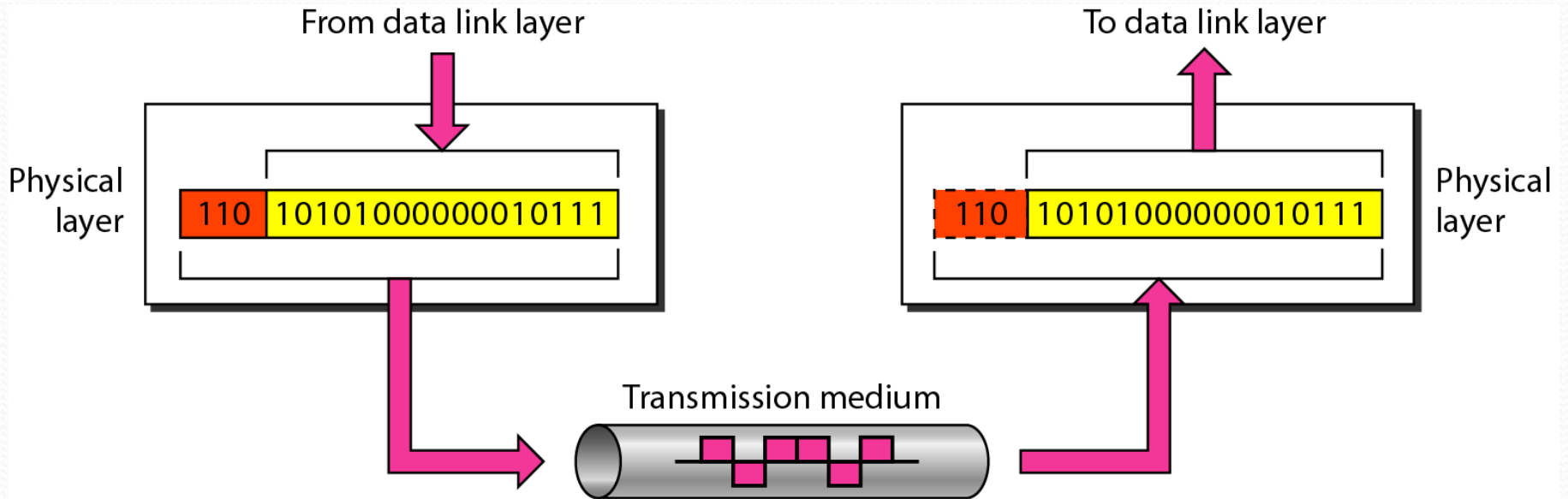



The physical layer is responsible for movements of individual bits from one hop (node) to the next. The physical layer is concerned with transmitting raw bits over a communication channel. It deals with the mechanical & electrical specifications of the interface and transmission medium.

Responsibilities of Physical layer

- Physical characteristics of interfaces & medium.
- Representation of bits.
- Data rate.
- Synchronization of bits.
- Line configuration.
- Physical topology.
- Transmission mode.

Figure 2.6 Data link layer

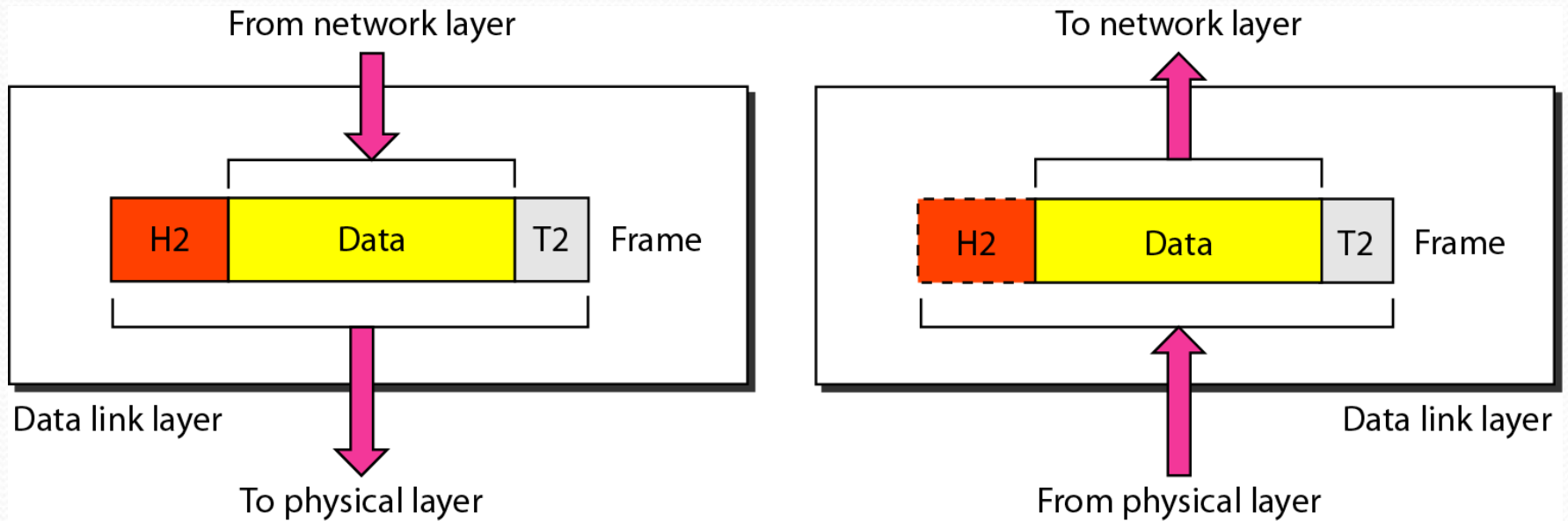

The data link layer is responsible for moving frames from one hop (node) to the next. The main task of this layer is to transform a raw transmission facility into a line that appears free of undetected transmission errors to the network layer. It accomplishes this task by breaking the input data into frames and transmit the frames sequentially. The receiver confirms correct receipt of each frame by sending back an ACK frame.

Responsibilities of Data link layer

- Framing.
- Physical addressing.
- Flow control.
- Error control.
- Access control.

Hop-to-hop delivery

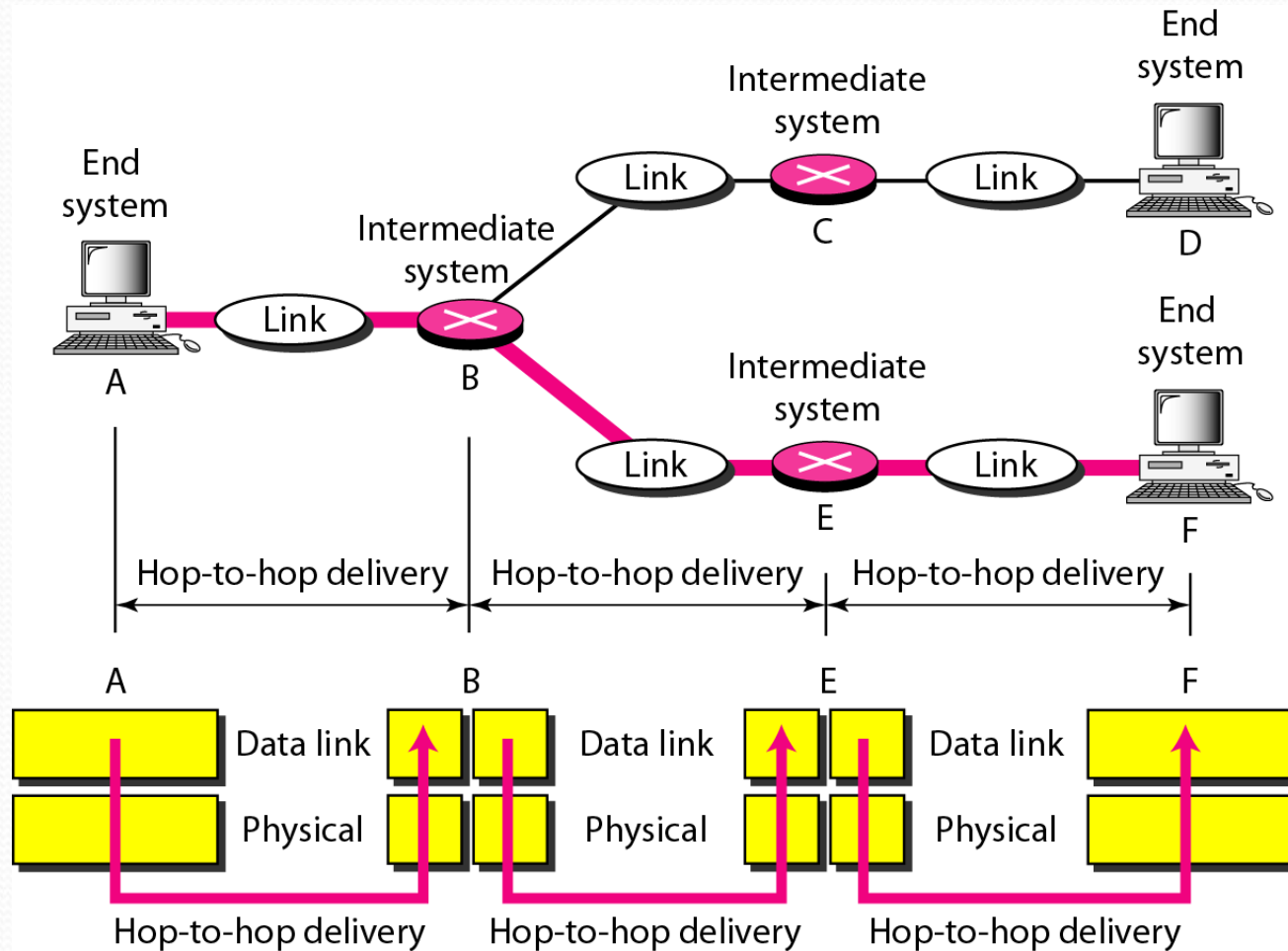

Network layer

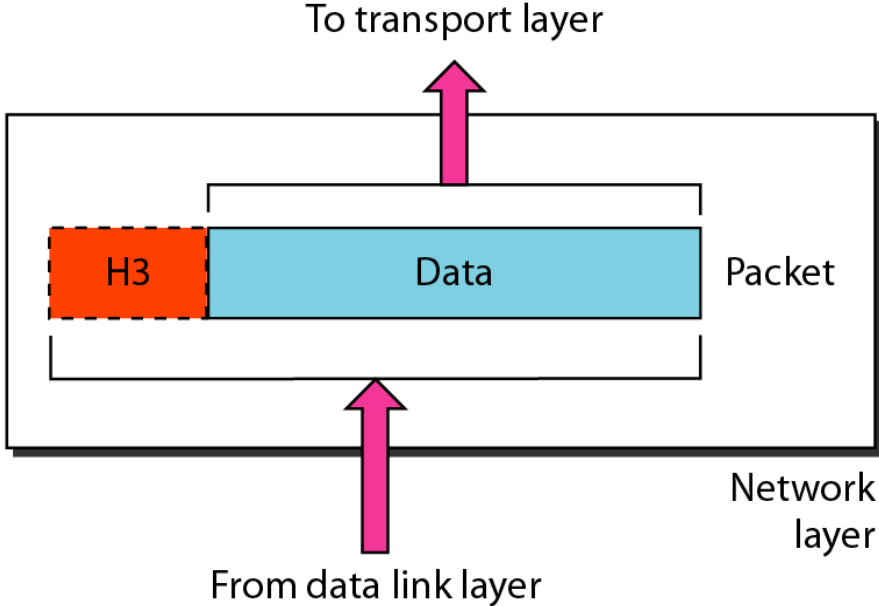
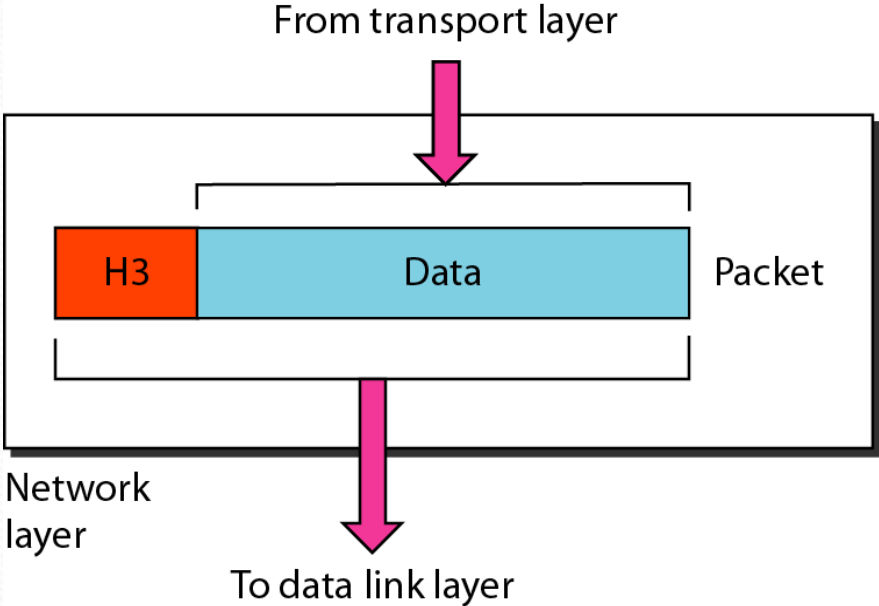

The network layer is responsible for the delivery of individual packets from the source host to the destination host. This layer controls the operation of subnet and responsible for the source-to-destination delivery of a packet across multiple networks. A key design issue is determining how packets are routed from source to destination. Routes can be based on static tables.

Responsibilities of Network layer

- Logical addressing.
- Routing (Router/Switch).

Source-to-destination delivery

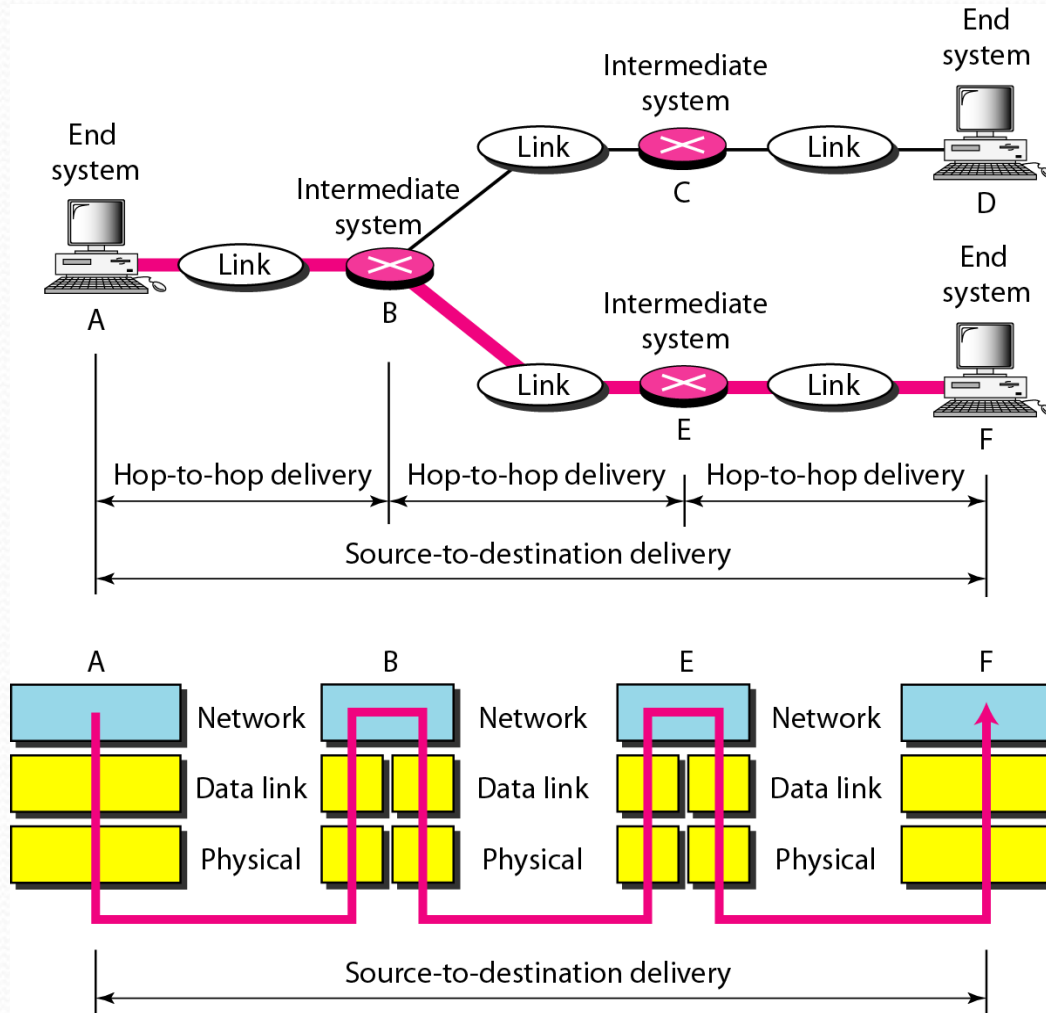

Transport layer

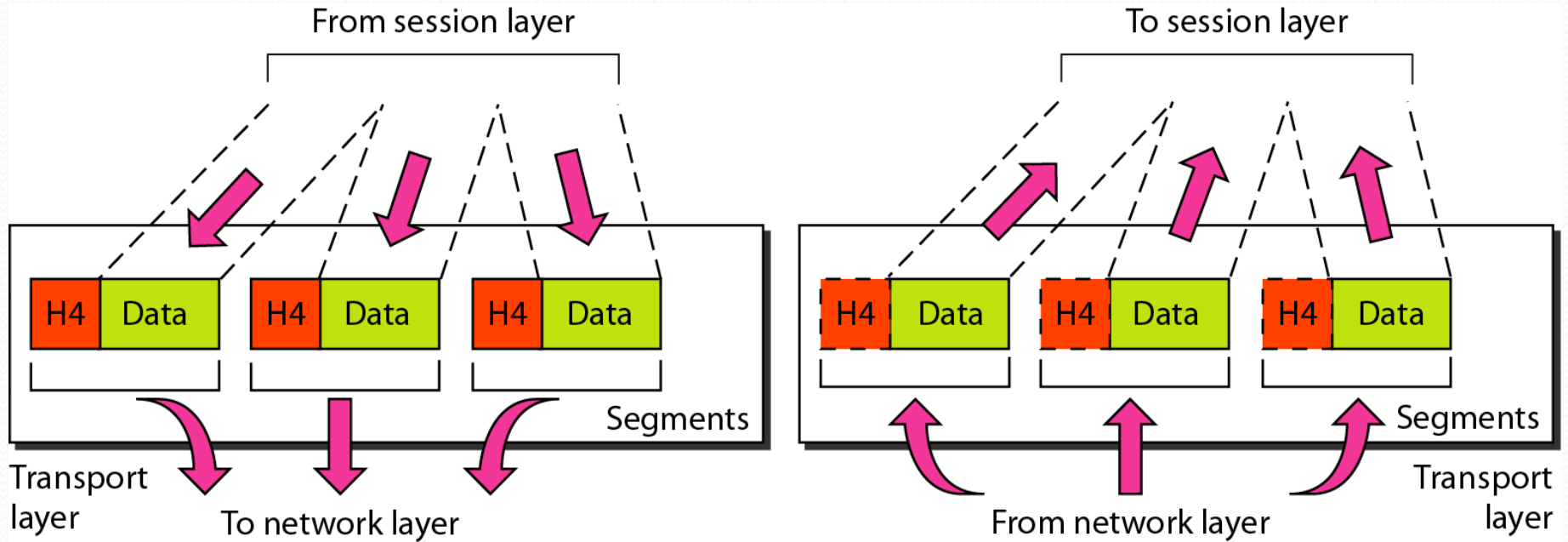



The transport layer is responsible for the delivery of a message from one process to another (process to process). The basic function of transport layer is to accept data from above, split it up into smaller units if needed, pass these to the network layer, & ensure that the pieces all arrive correctly at the other end.

Responsibilities of Transport layer

- Service-Point addressing.
- Segmentation & reassembly.
- Connection control.
- Flow control.
- Error control.

Reliable process-to-process delivery of a message

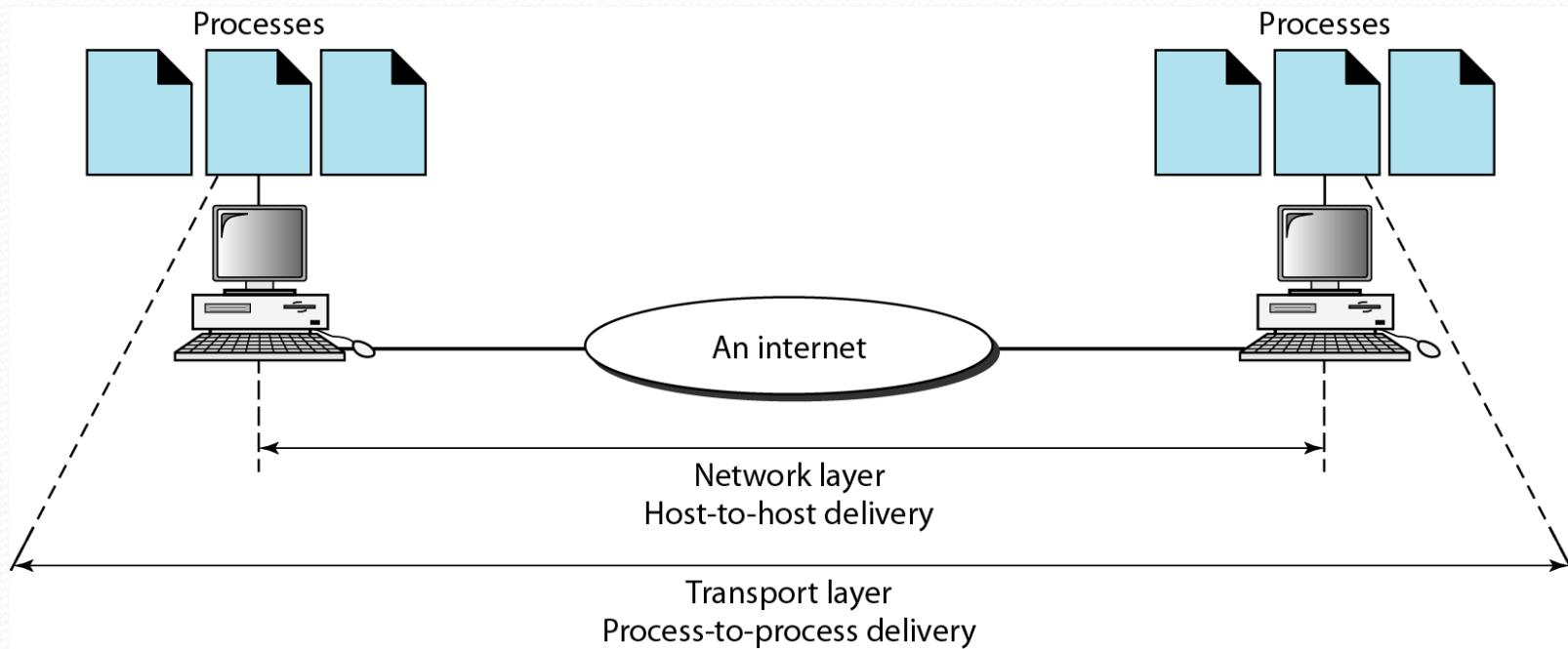

Session layer

From presentation layer

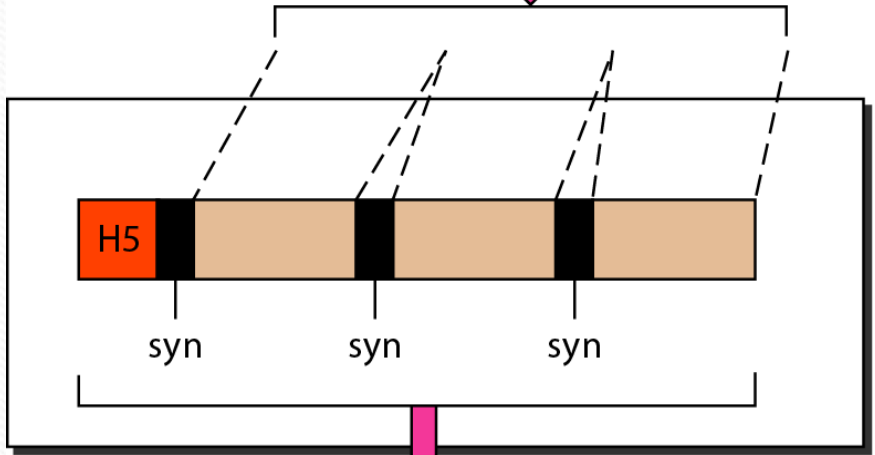

To transport layer

Session layer

To presentation layer

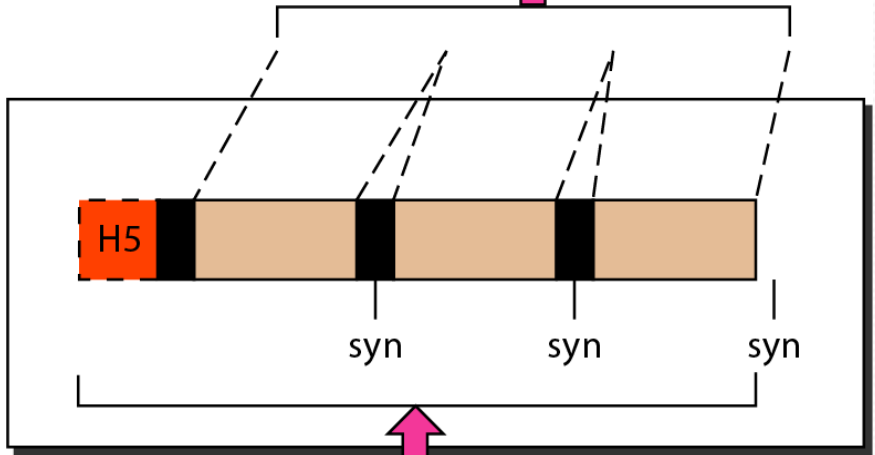
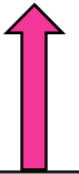

From transport layer

Session layer





The session layer allows users on different machines to establish sessions between them. This layer is the network dialog controller. It establishes, maintains, and synchronizes the interaction among communication system and also responsible for dialog control and synchronization.

Responsibilities of Session layer

- Dialog control.
- Synchronization.

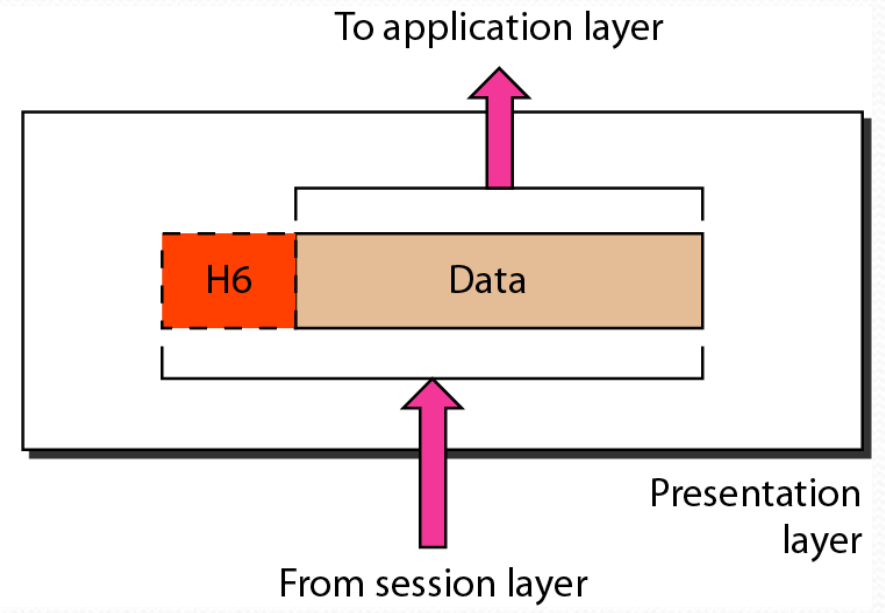
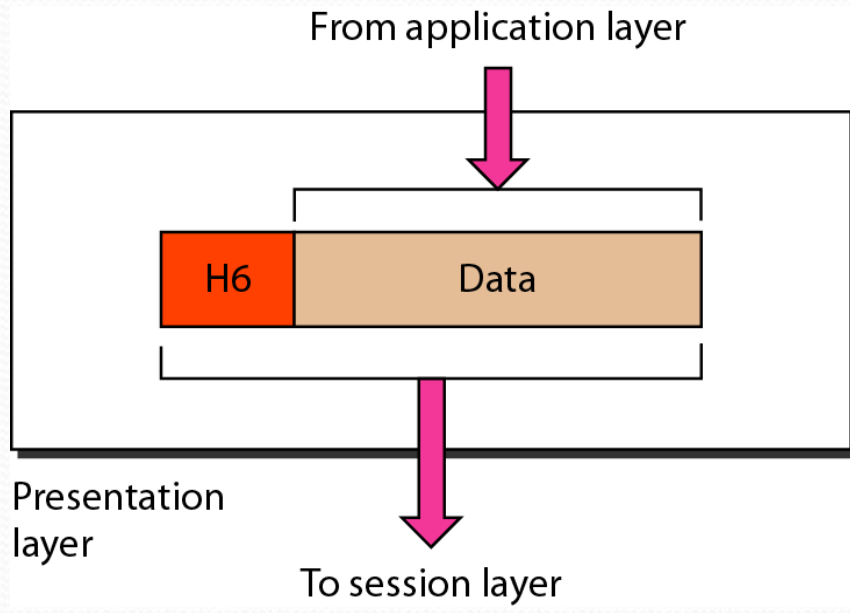
Presentation layer







The presentation layer is concerned with the syntax and semantics of information exchanged between two systems.

Responsibilities of Presentation layer

- Translation.
- Compression.
- Encryption.

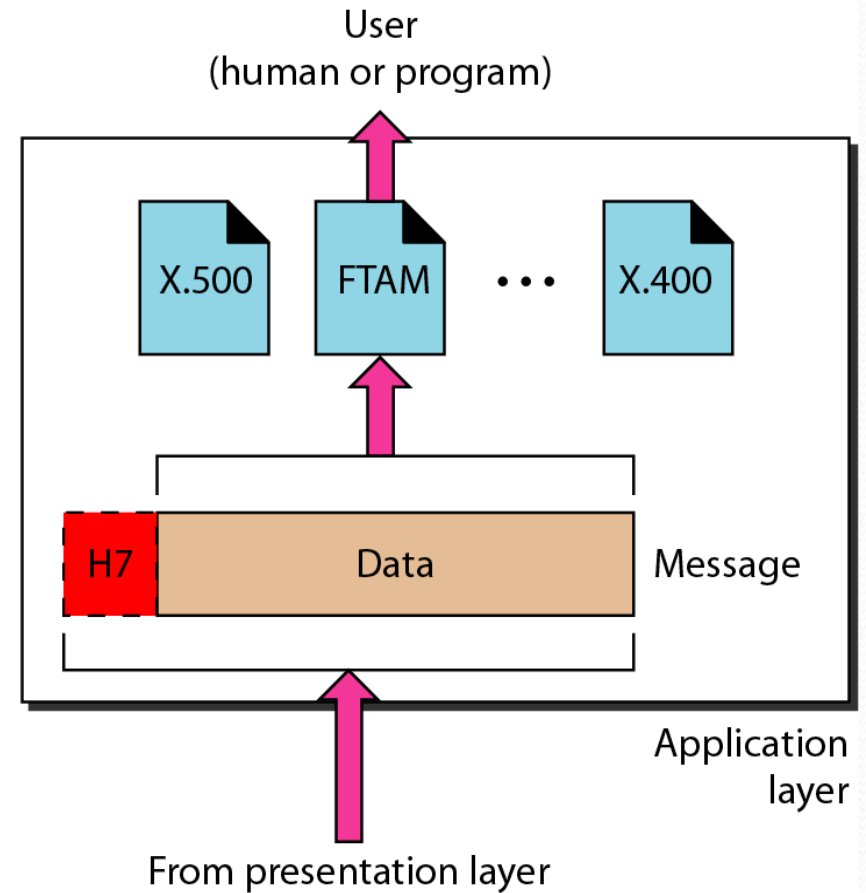
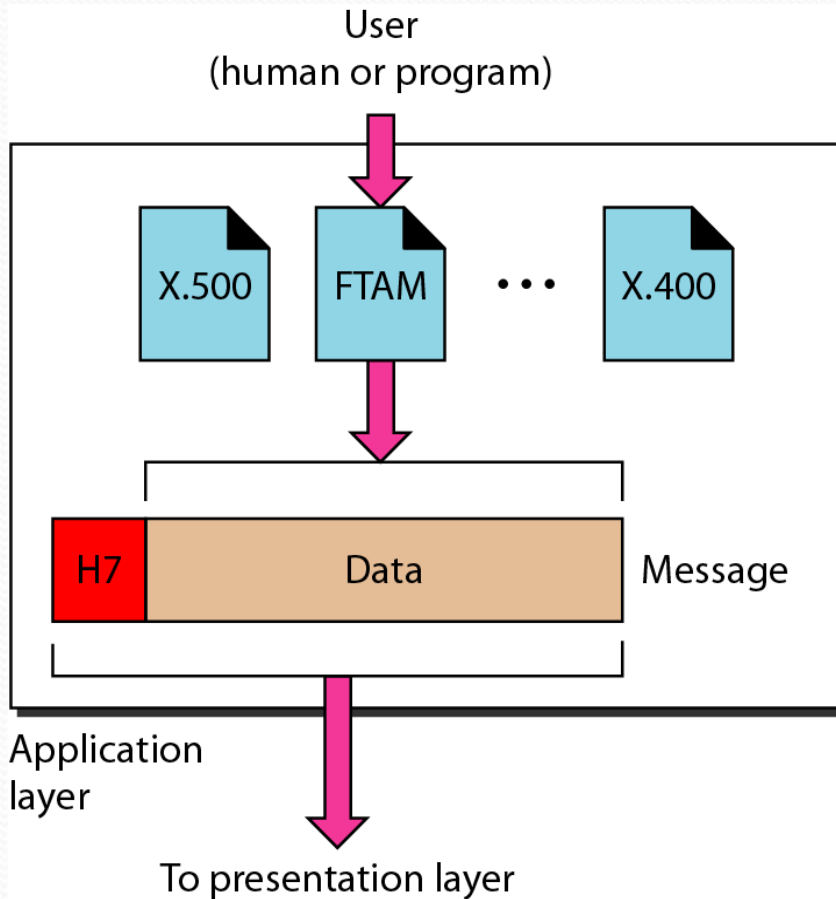
Application layer





The application layer is responsible for providing services to the user. This layer contains a variety of protocols that are commonly needed by users like HTTP.

Responsibilities of Application layer

- Network virtual terminal.
- File transfer, access and management.
- Mail/Directory services.

Summary of layers

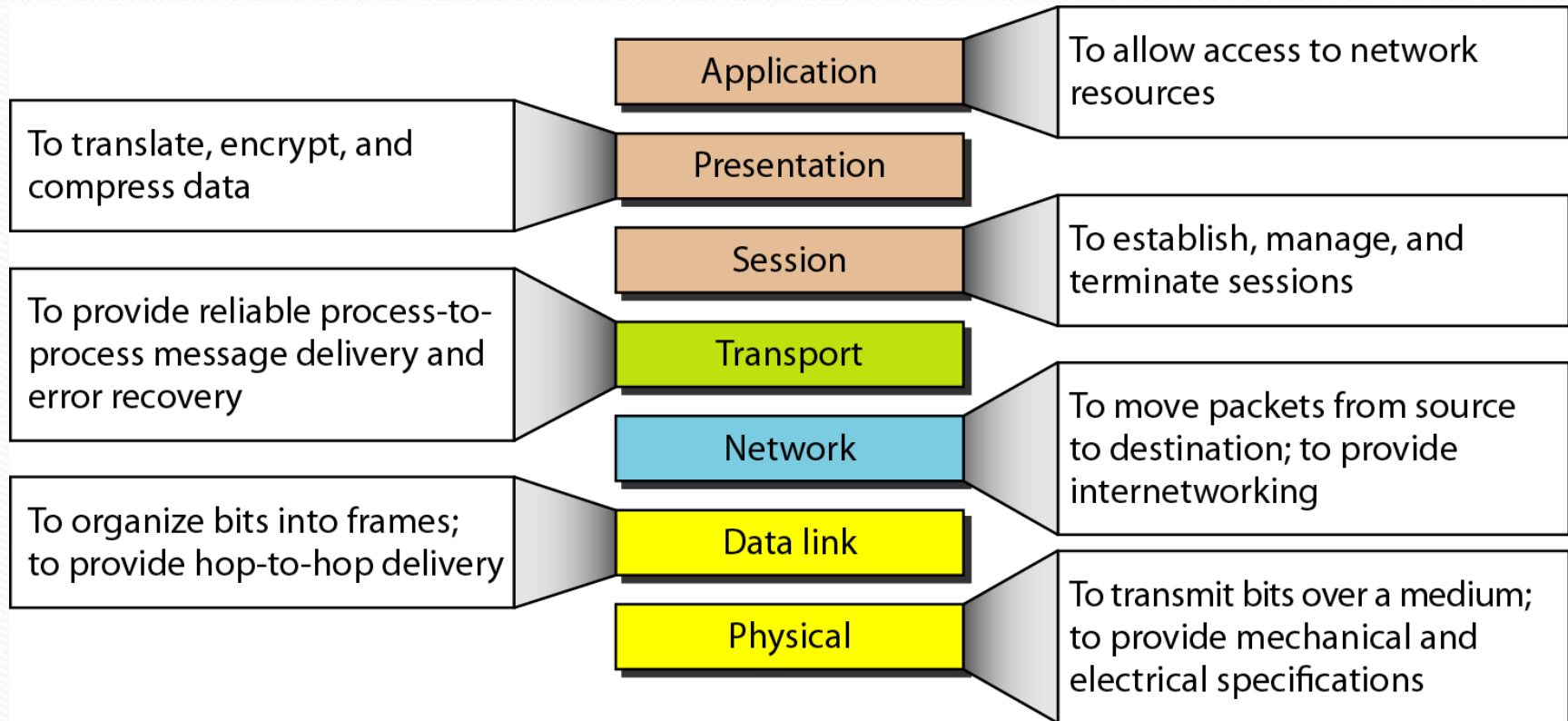

TCP/IP PROTOCOL SUITE

*The layers in the **TCP/IP protocol suite** do not exactly match those in the OSI model. The original TCP/IP protocol suite was defined as having four layers: **host-to-network, internet, transport, and application**. However, when TCP/IP is compared to OSI, we can say that the TCP/IP protocol suite is made of five layers: **physical, data link, network, transport, and application**.*

Figure 2.16 TCP/IP and OSI model

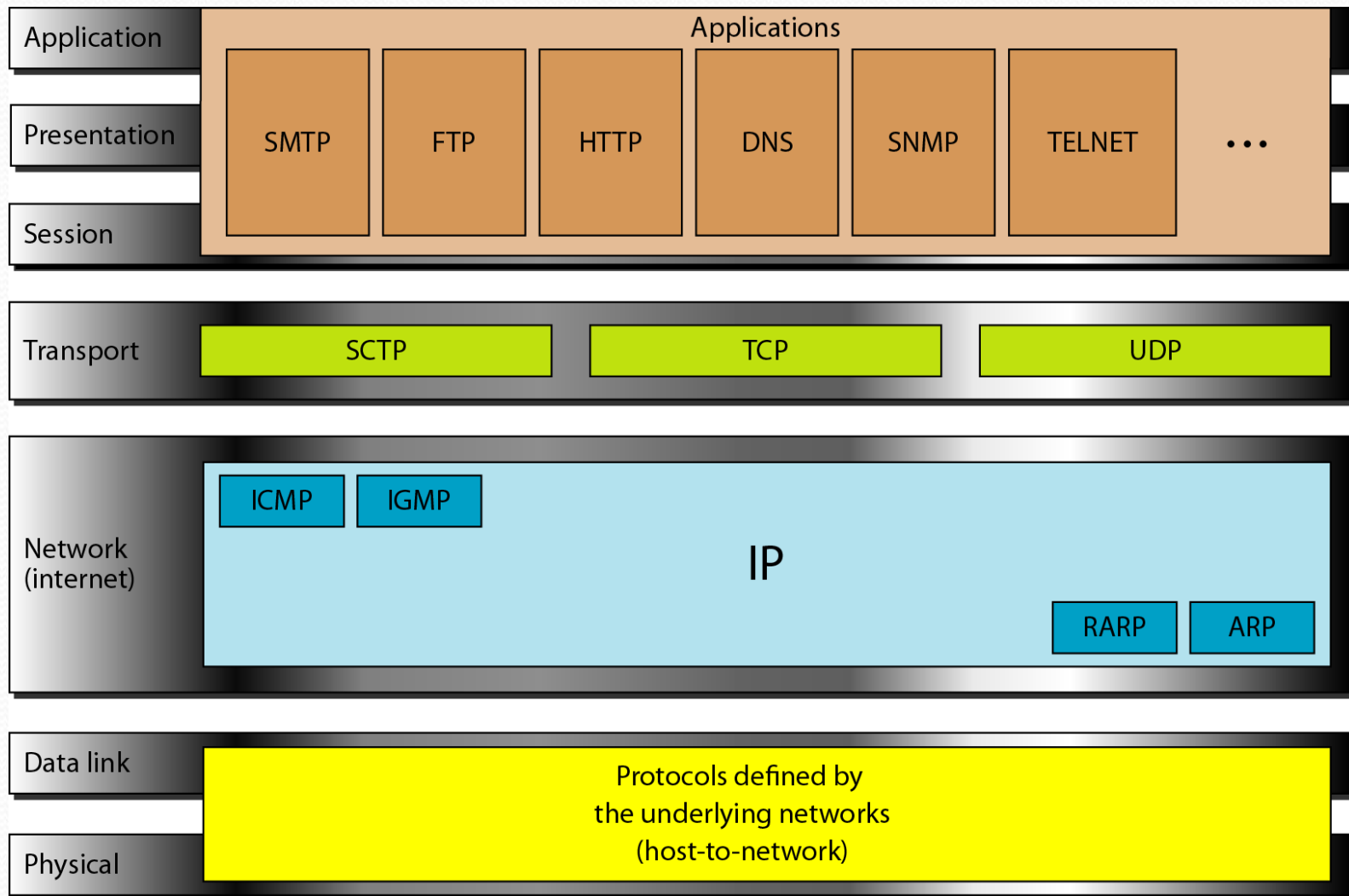

ADDRESSING

Four levels of addresses are used in an internet employing the TCP/IP protocols:

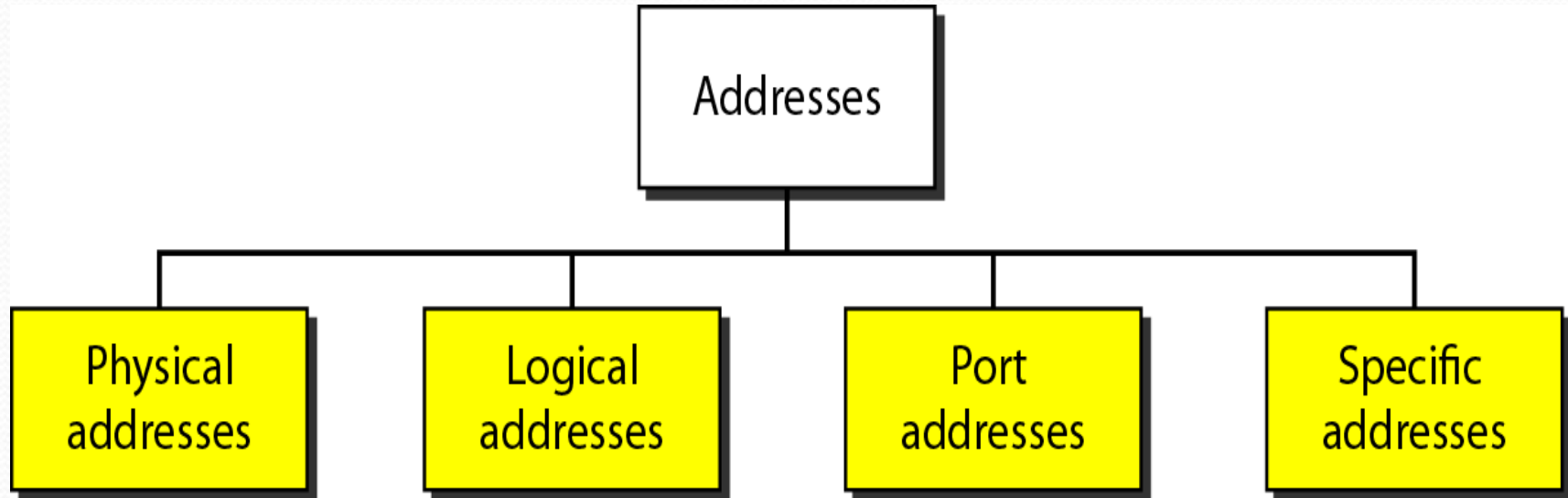

Relationship of layers and addresses in TCP/IP

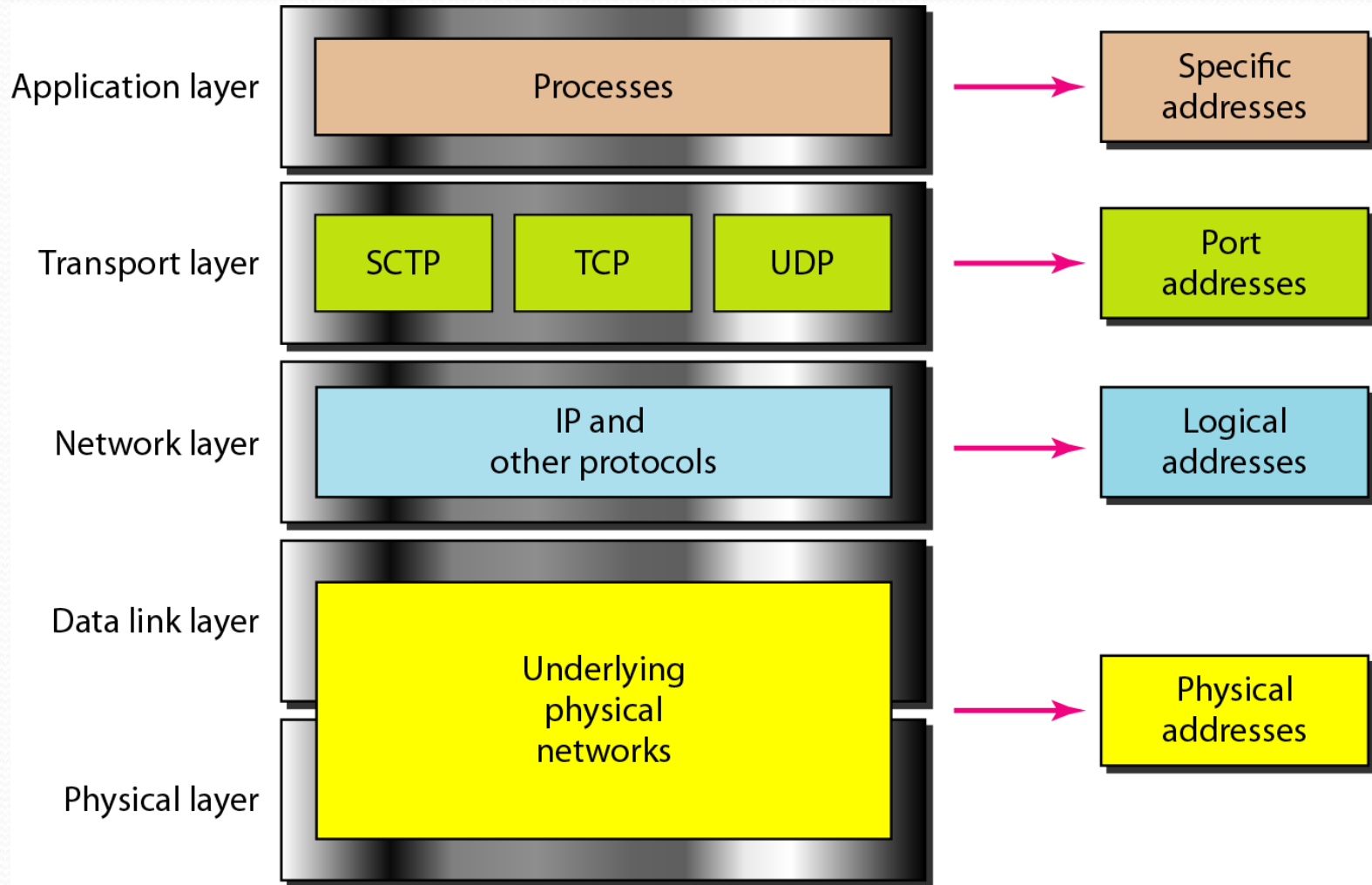

Physical Address

In Figure a node with physical address 10 sends a frame to a node with physical address 87. The two nodes are connected by a link (bus topology LAN). As the figure shows, the computer with physical address 10 is the sender, and the computer with physical address 87 is the receiver.

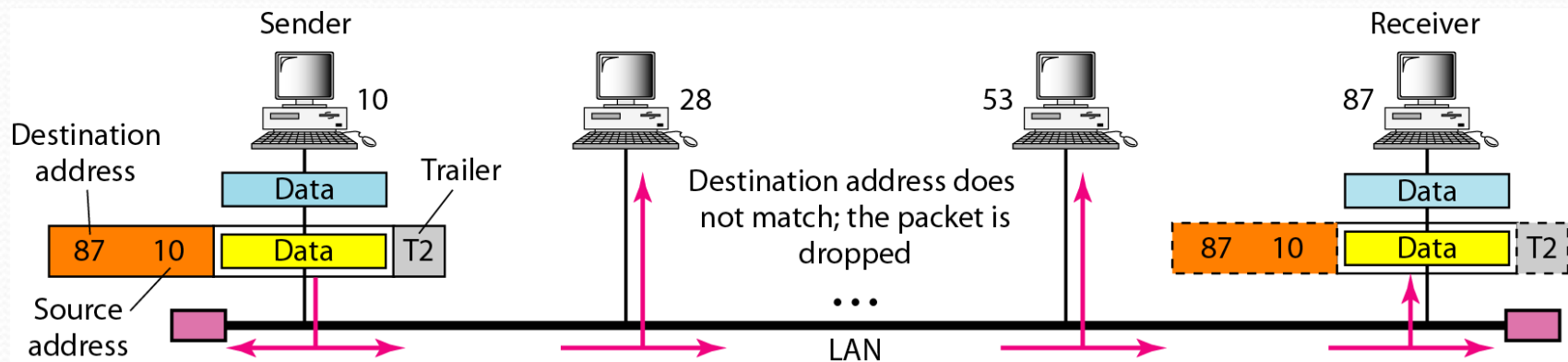



Example 2.2

Most local-area networks use a 48-bit (6-byte) physical address written as 12 hexadecimal digits; every byte (2 hexadecimal digits) is separated by a colon, as shown below:

07:01:02:01:2C:4B

A 6-byte (12 hexadecimal digits) physical address.

IP addresses

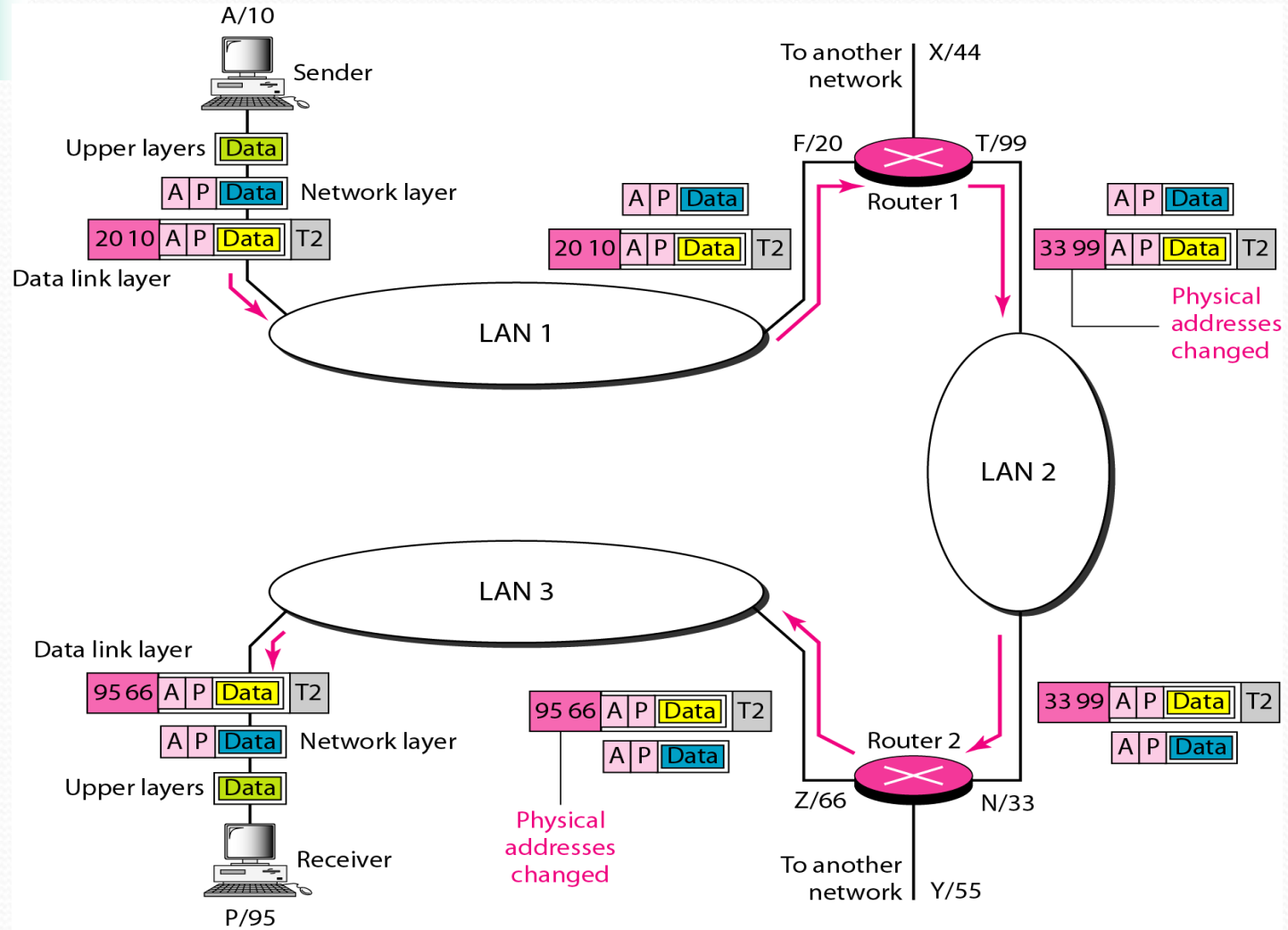
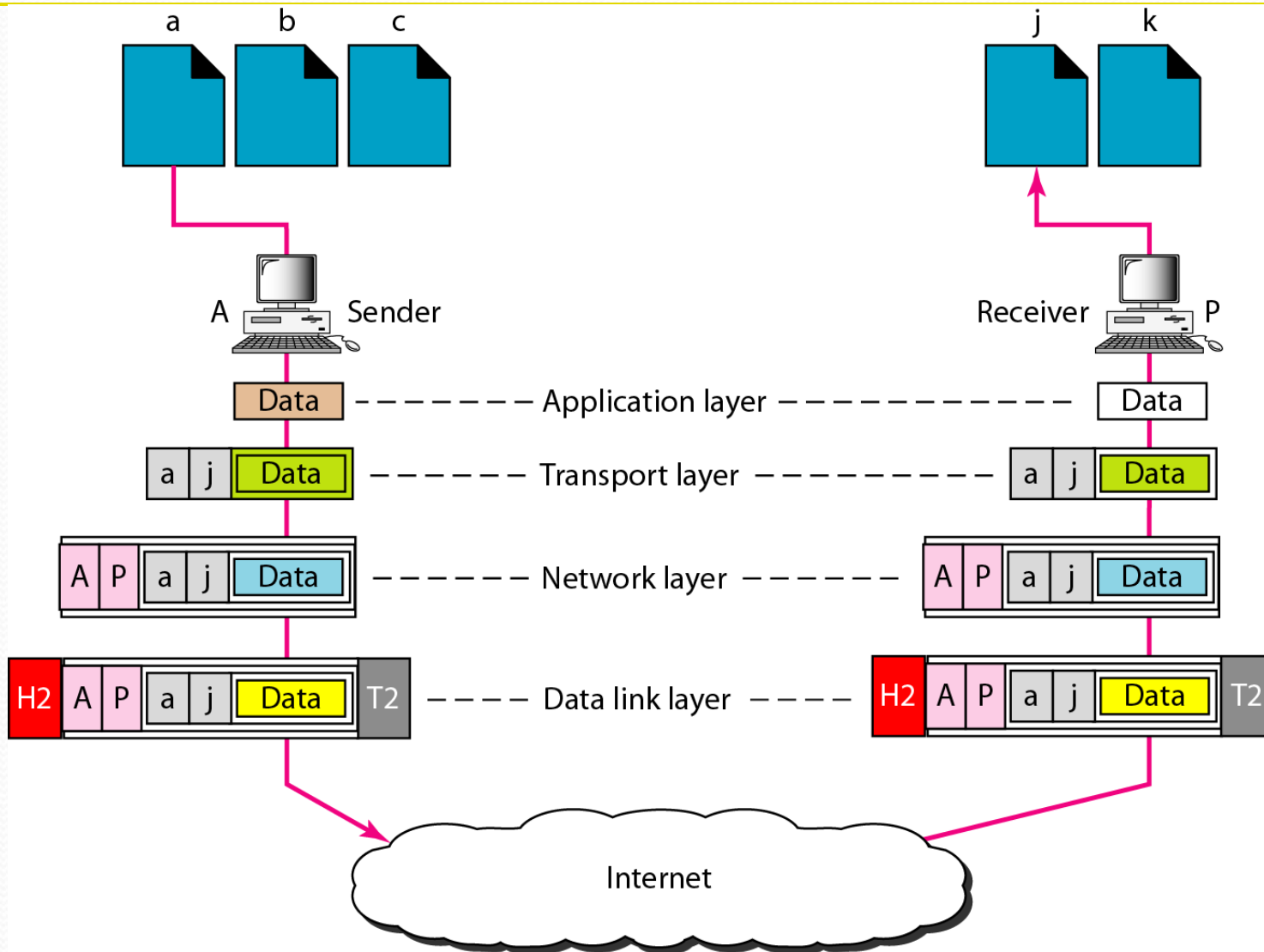

Figure shows a part of an internet with two routers connecting three LANs. Each device (computer or router) has a pair of addresses (logical and physical) for each connection. In this case, each computer is connected to only one link and therefore has only one pair of addresses. Each router, however, is connected to three networks (only two are shown in the figure). So each router has three pairs of addresses, one for each connection.



Port Address

Figure shows two computers communicating via the Internet. The sending computer is running three processes at this time with port addresses a, b, and c. The receiving computer is running two processes at this time with port addresses j and k. Process a in the sending computer needs to communicate with process j in the receiving computer. Note that although physical addresses change from hop to hop, logical and port addresses remain the same from the source to destination.



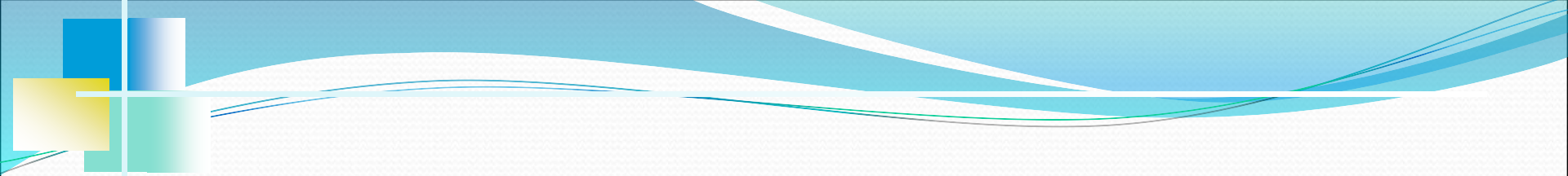

The physical addresses will change from hop to hop,
but the logical addresses usually remain the same.



A port address is a 16-bit address represented by one decimal number as shown.

753

A 16-bit port address represented
as one single number.

A hand-drawn illustration of a pen writing the words "Thank you" in a cursive script on a white surface. The pen is positioned at the end of the word "you", and the text is written in a dark, slightly blurred ink. The background of the illustration is a light gray with a fine grid pattern.

Thank you